

A member of **TOPWERK**



MASCHINEN UND FORMEN

ZUR HERSTELLUNG VON
ROHREN, SCHÄCHTEN UND
FERTIGTEILEN AUS BETON

Führend durch Innovation,
Erfahrung durch Tradition
seit 1862

VISION

MISSION



550+

Erfolgreiche
Kundenprojekte

70

Zufriedene Kunden
in über 70 Ländern

100+

Mitarbeiter
kümmern sich um
den Erfolg Ihrer
Projekte

4

An 4 Standorten
in Deutschland
für Sie tätig

750+

Maschinen
weltweit
im Einsatz

und Service für Ihre
Bestandsanlagen

BETONFERTIGEILE FÜR INFRA TRUKUR PROJEKE



KANALISATION

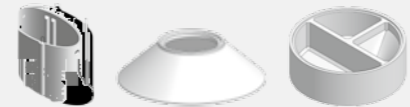

KLÄRTECHNIK UND REGENWASSERNUTZUNG

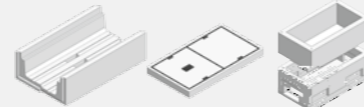

PRODUKTE FÜR DIE ENERGIEVERSORGUNG UND TELEKOMMUNIKATION



PRODUKTE FÜR DIE ENTWÄSSERUNG



FLÄCHIGE BETONPRODUKTE

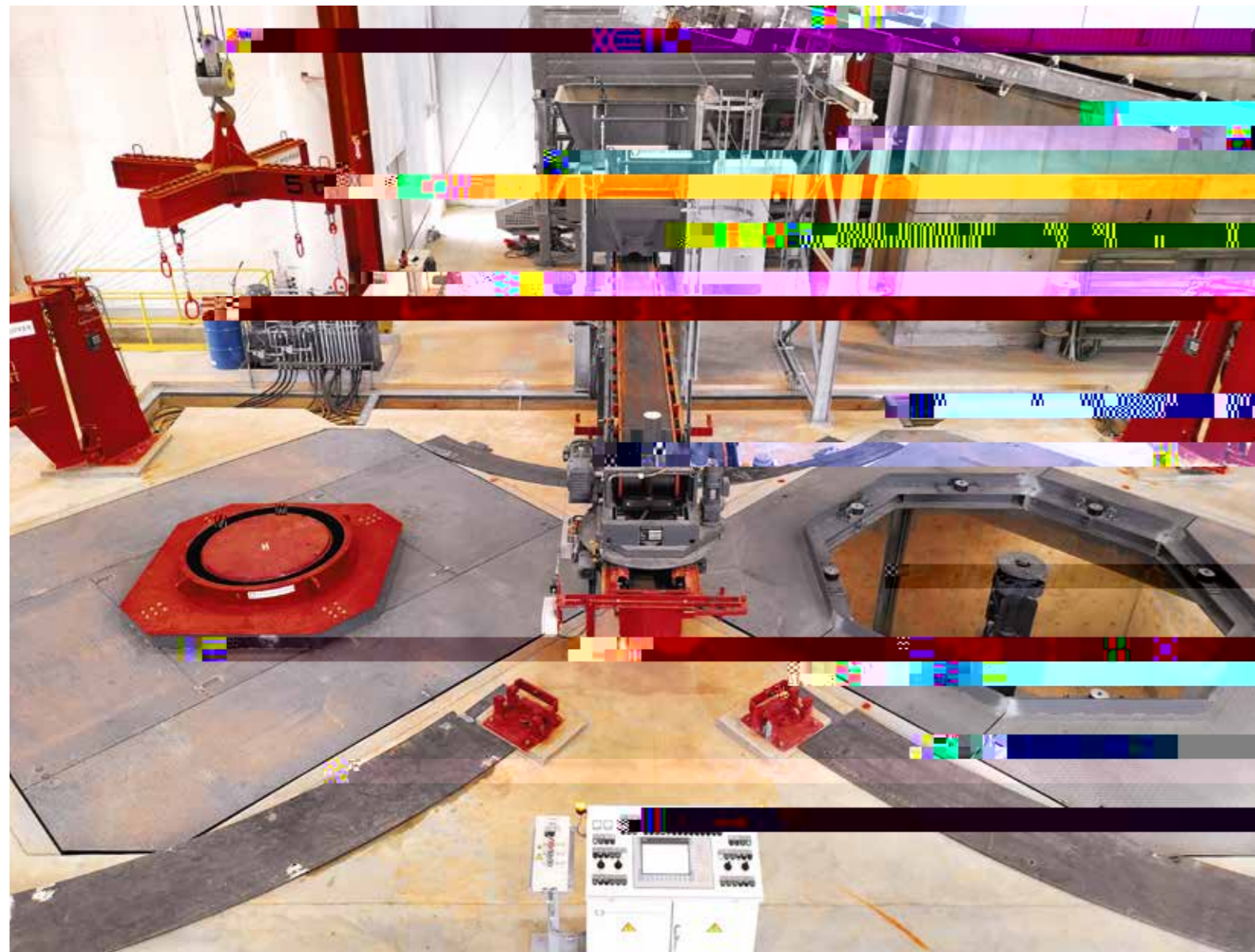

MASCHINEN UND FORMEN

ZUR HERSTELLUNG VON
ROHREN, SCHÄCHTEN UND FERTIGTEILEN AUS BETON

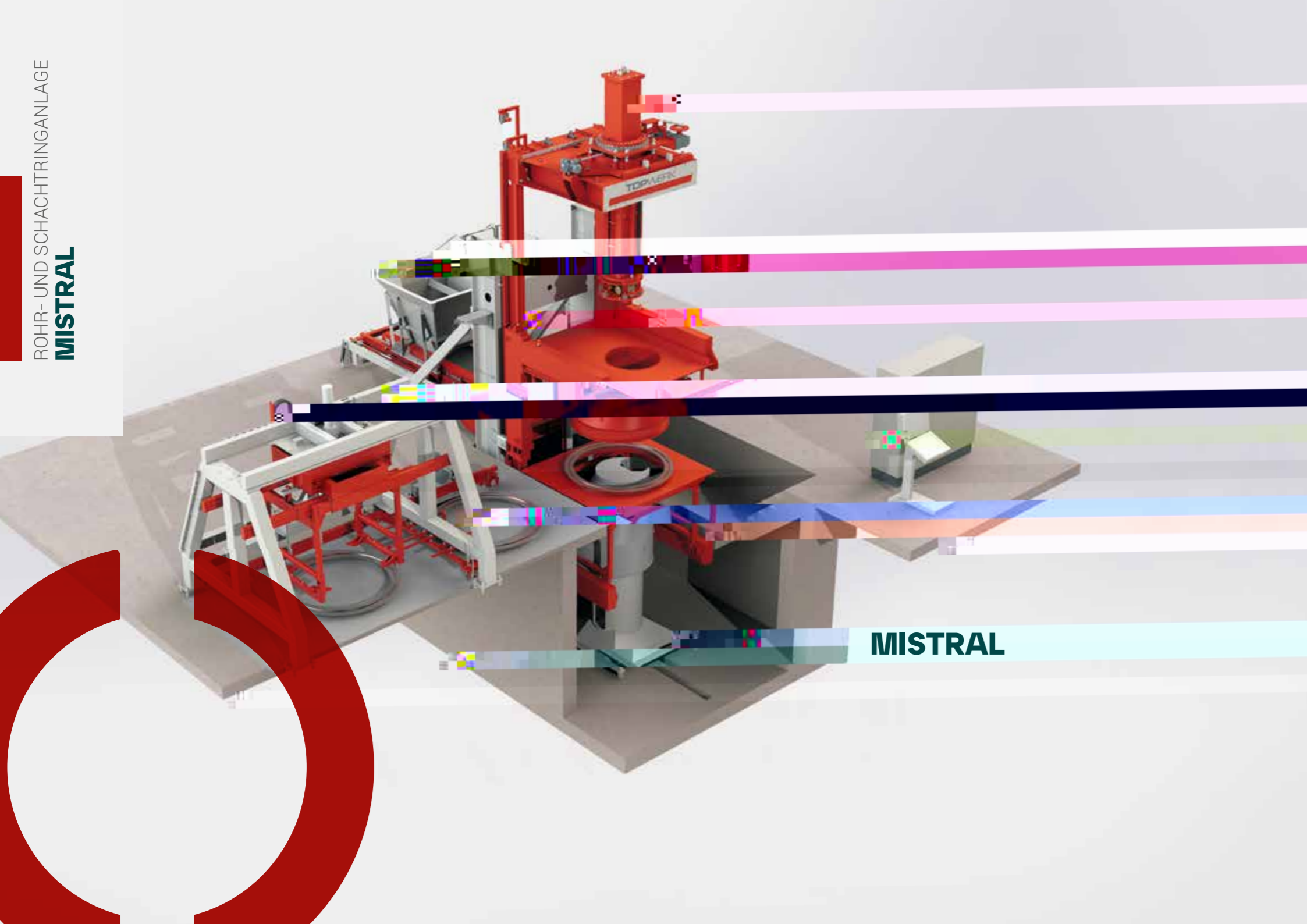

Bestens geeignet ist die MISTRAL zur Herstellung von

Produkten für die Kanalisation

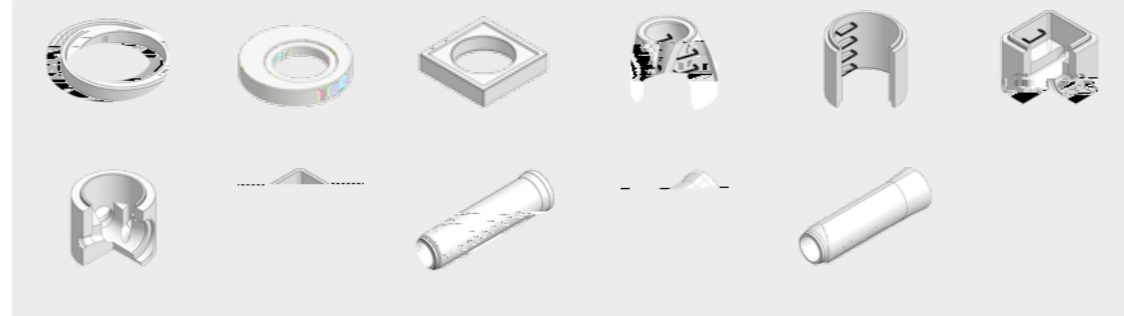

Produkten für die Klärtechnik und Regenwassernutzung



Produkten für die Entwässerung

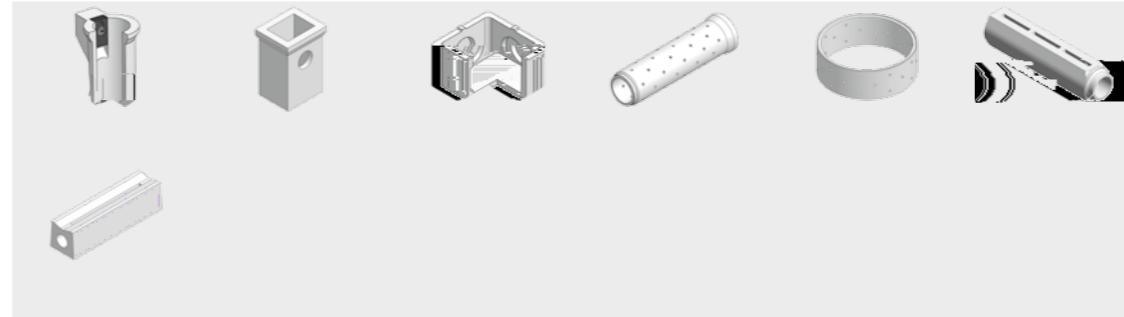

Produkten für die Energieversorgung und Telekommunikation

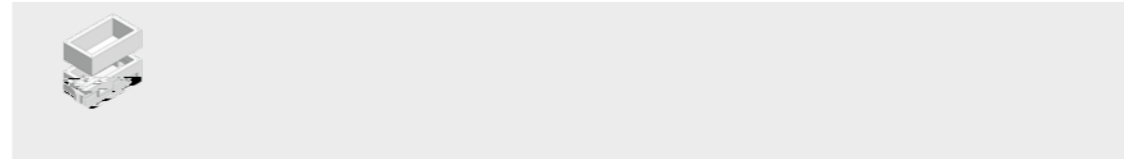

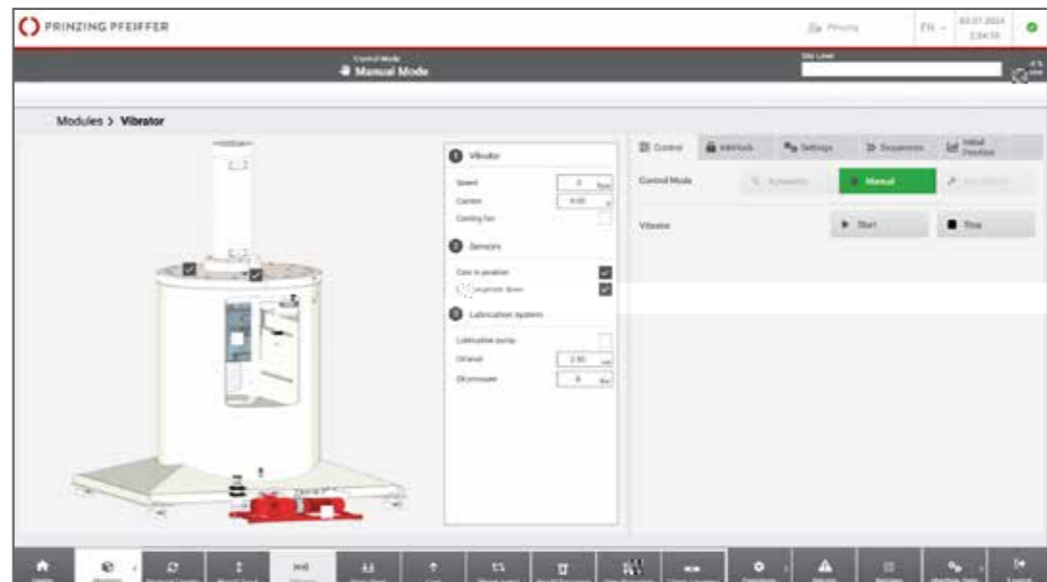
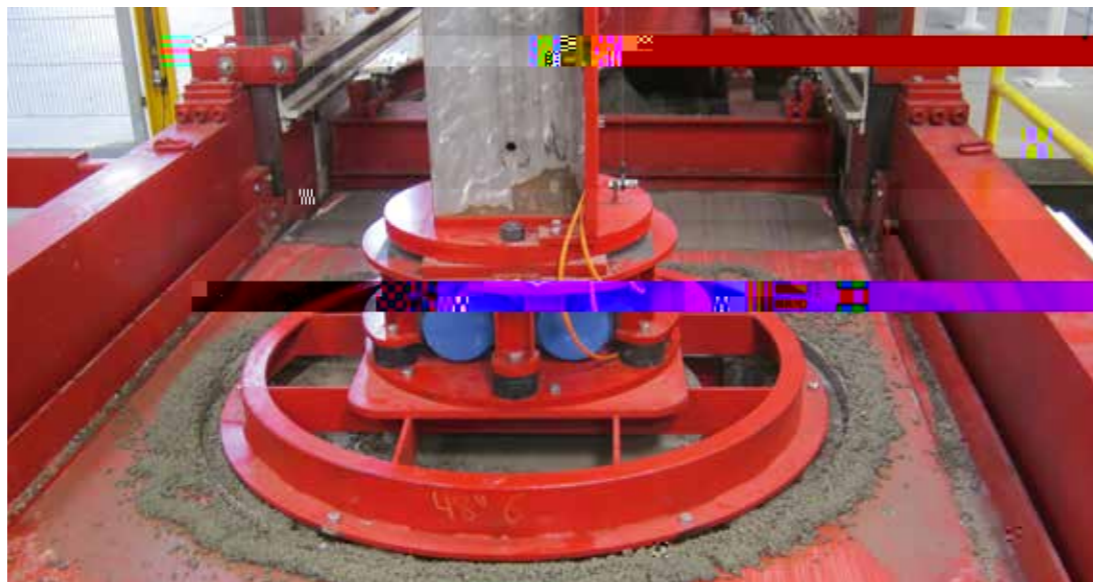

ERWEITERUNGSMÖGLICHKEITEN
DER MISTRAL

-
-
-
-
-
-
-
-
-
-

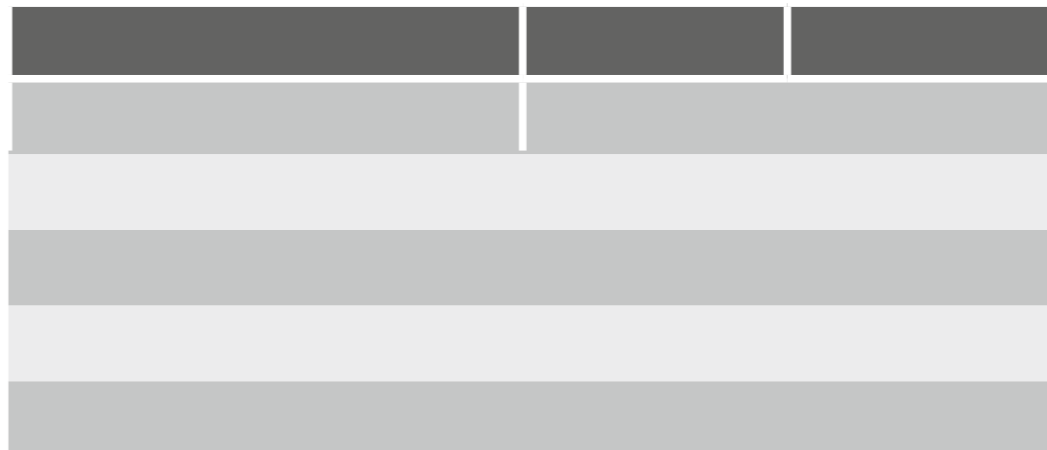

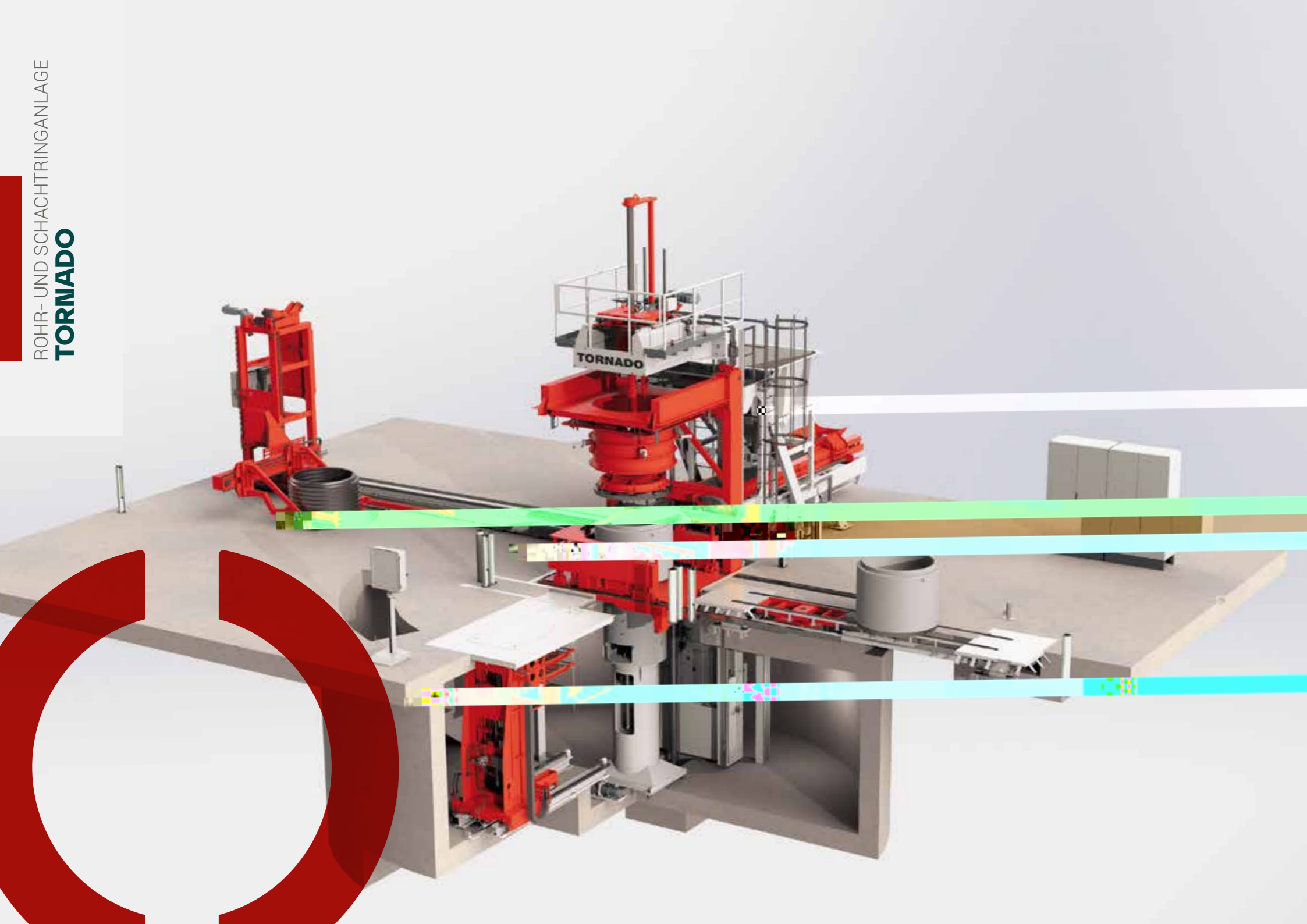

Bestens geeignet ist die TORNADO zur Herstellung von

Produkten für die Kanalisation

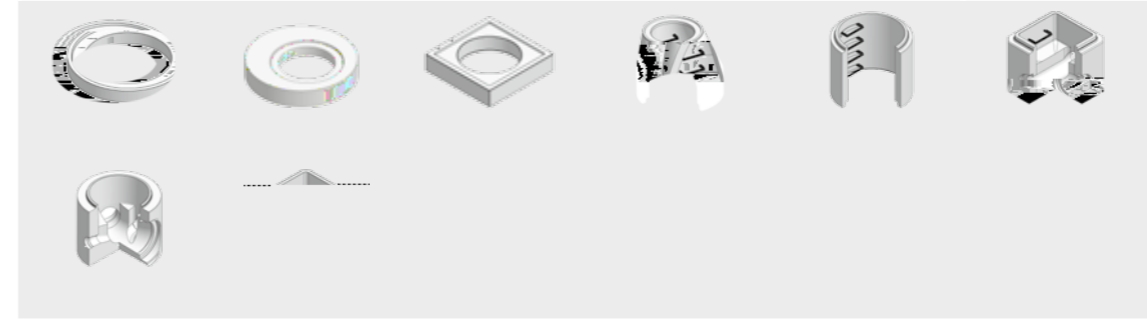

Produkten für die Klärtechnik und Regenwassernutzung

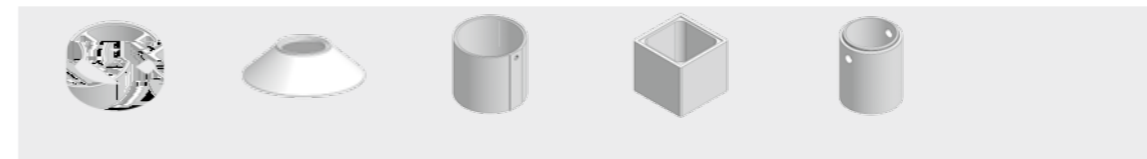

Produkten für die Entwässerung

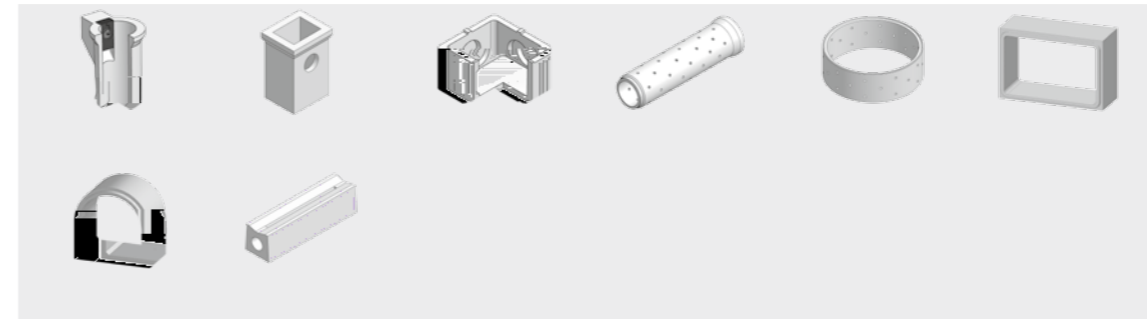

Produkten für die Energieversorgung und Telekommunikation

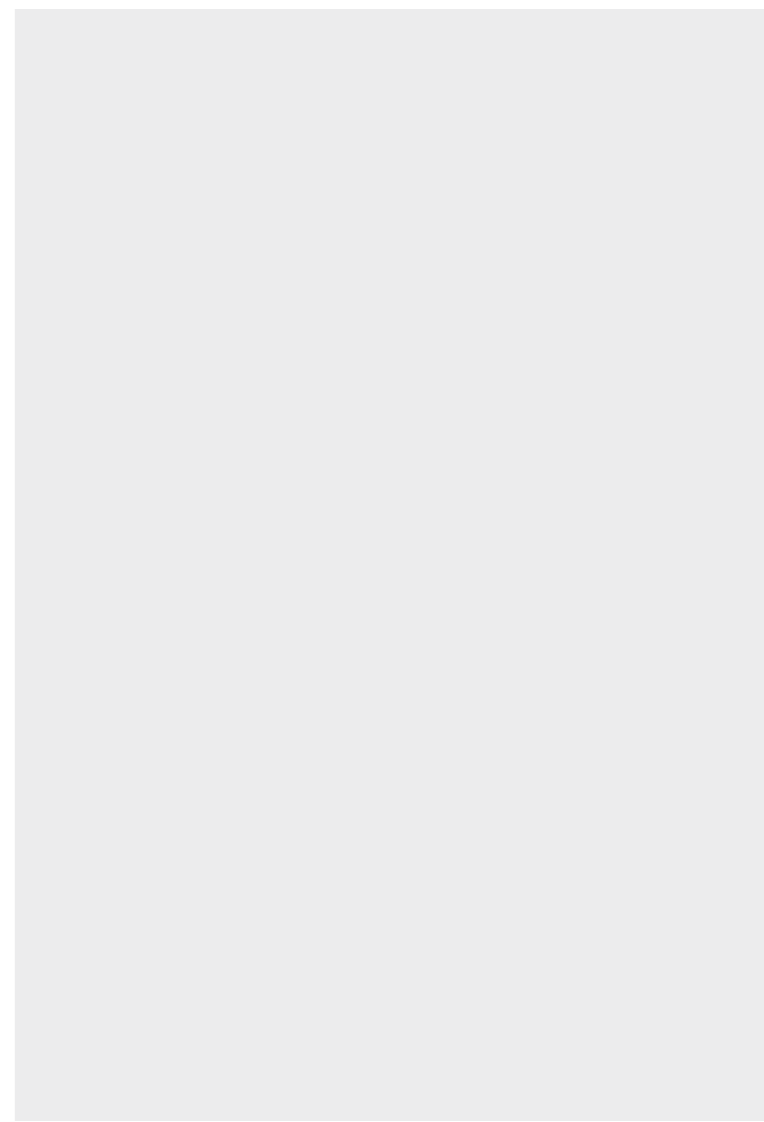
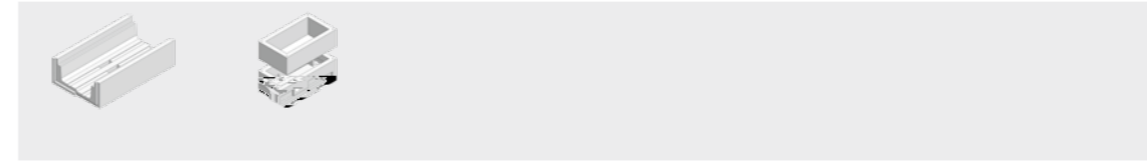



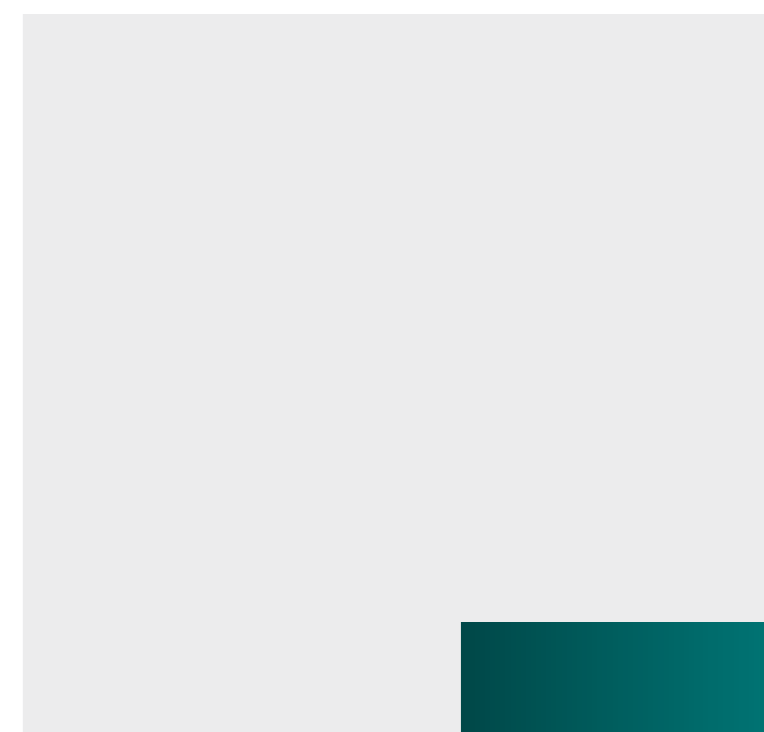
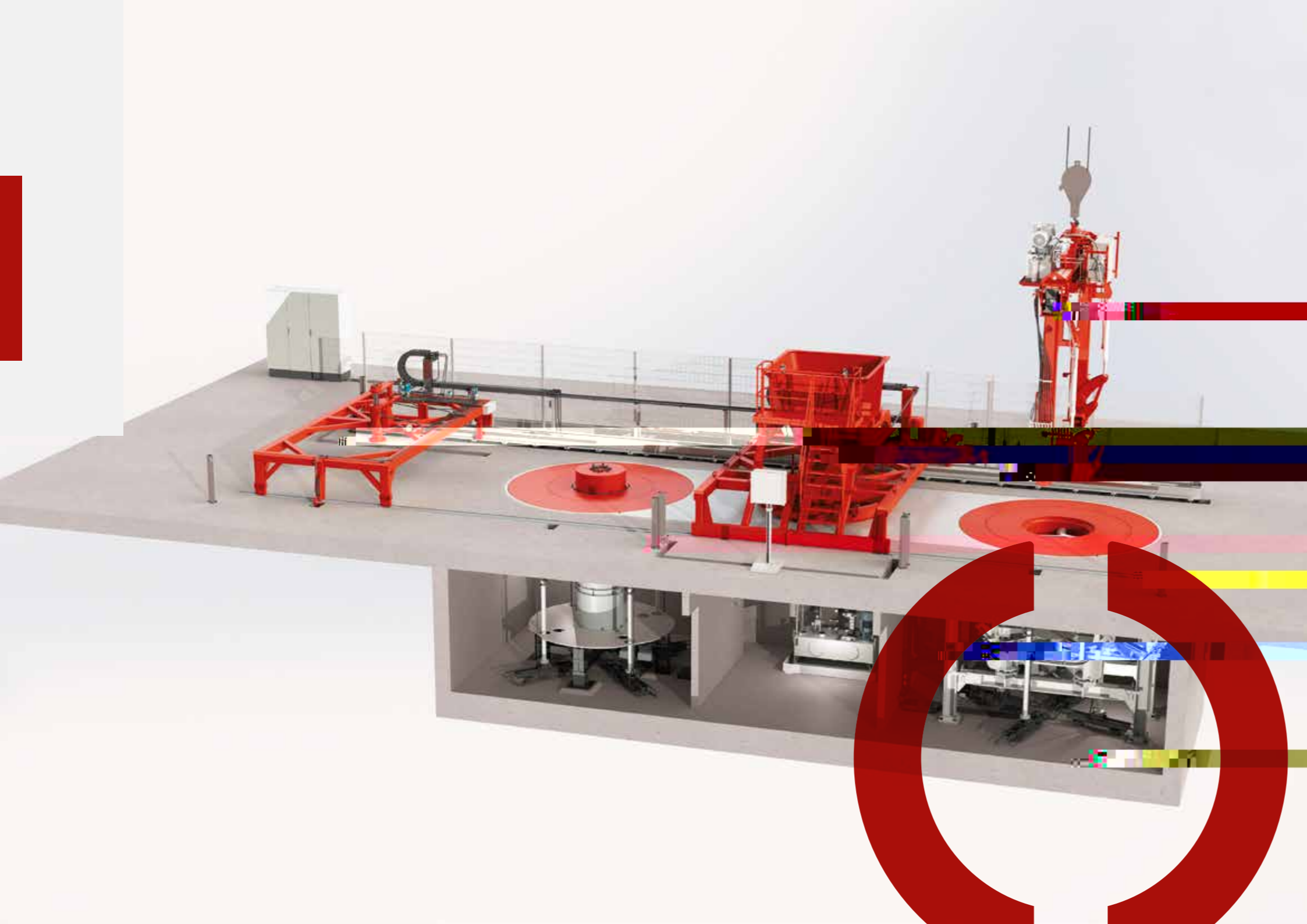

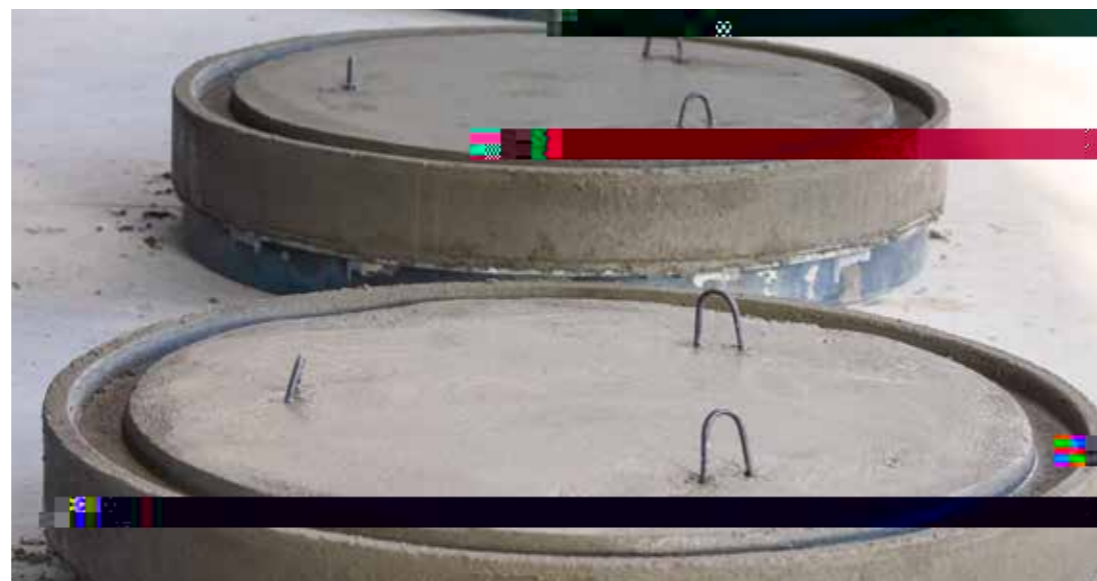

Bestens geeignet ist die ATLAS zur Herstellung von
Produkten für die Kanalisation



Produkten für die Klärtechnik und Regenwassernutzung

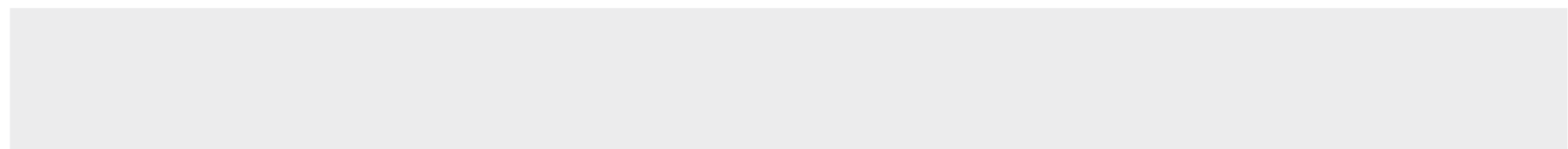
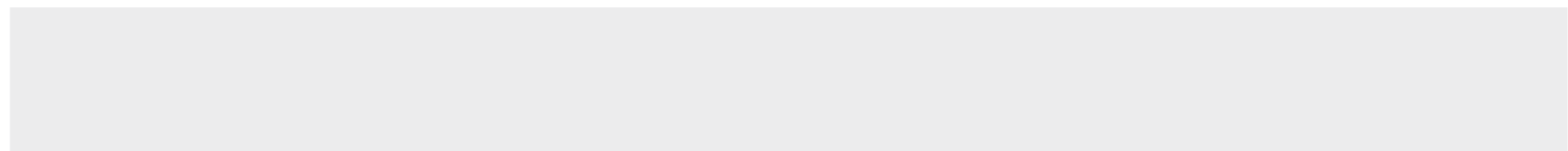
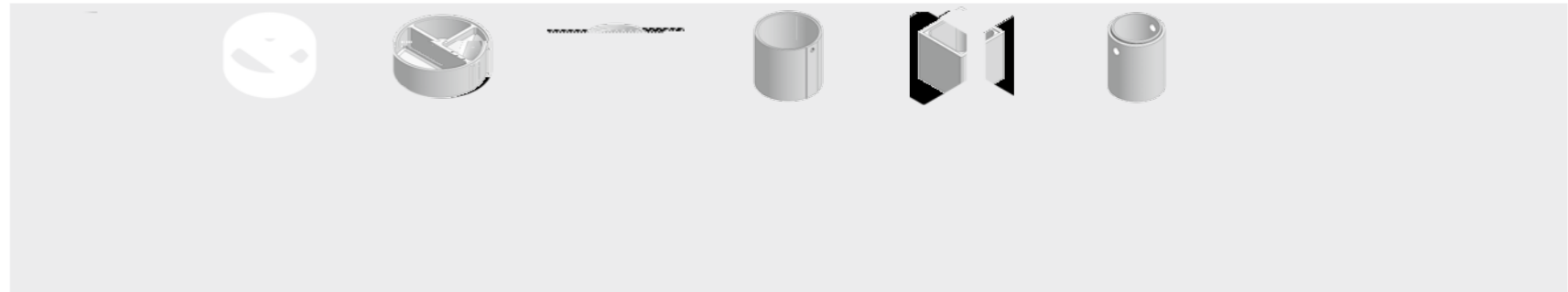



ATLAS 200/100

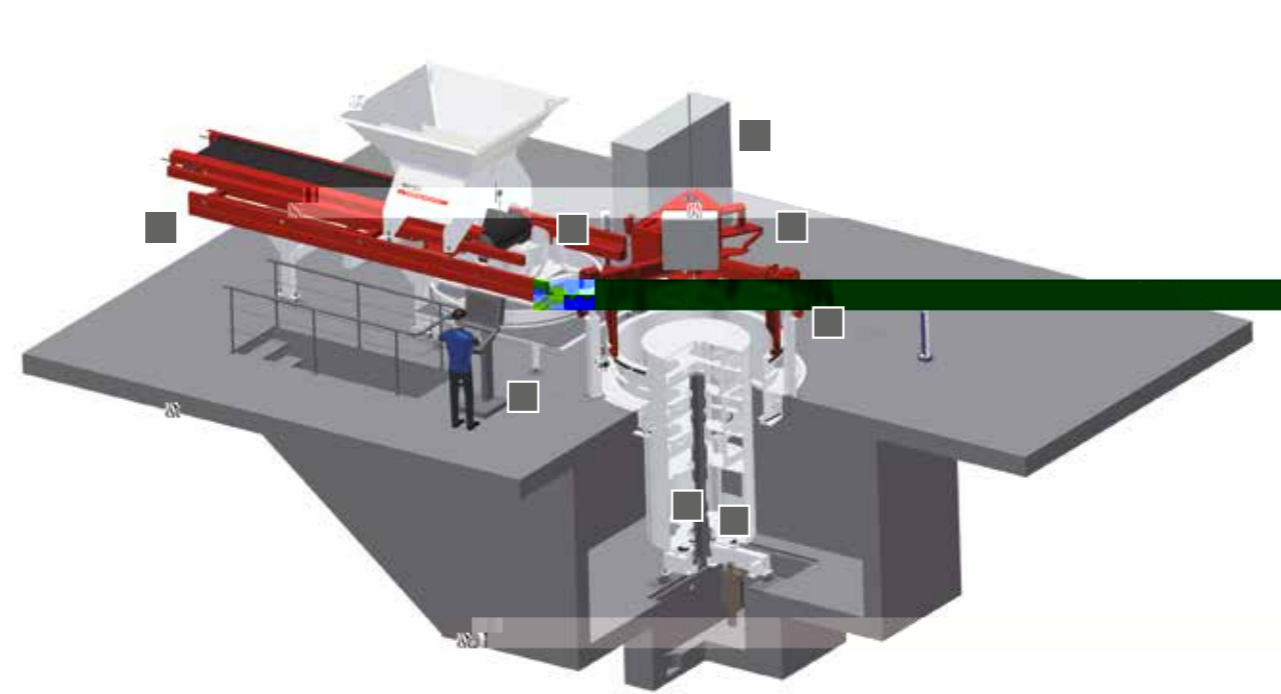

ATLAS 200/250

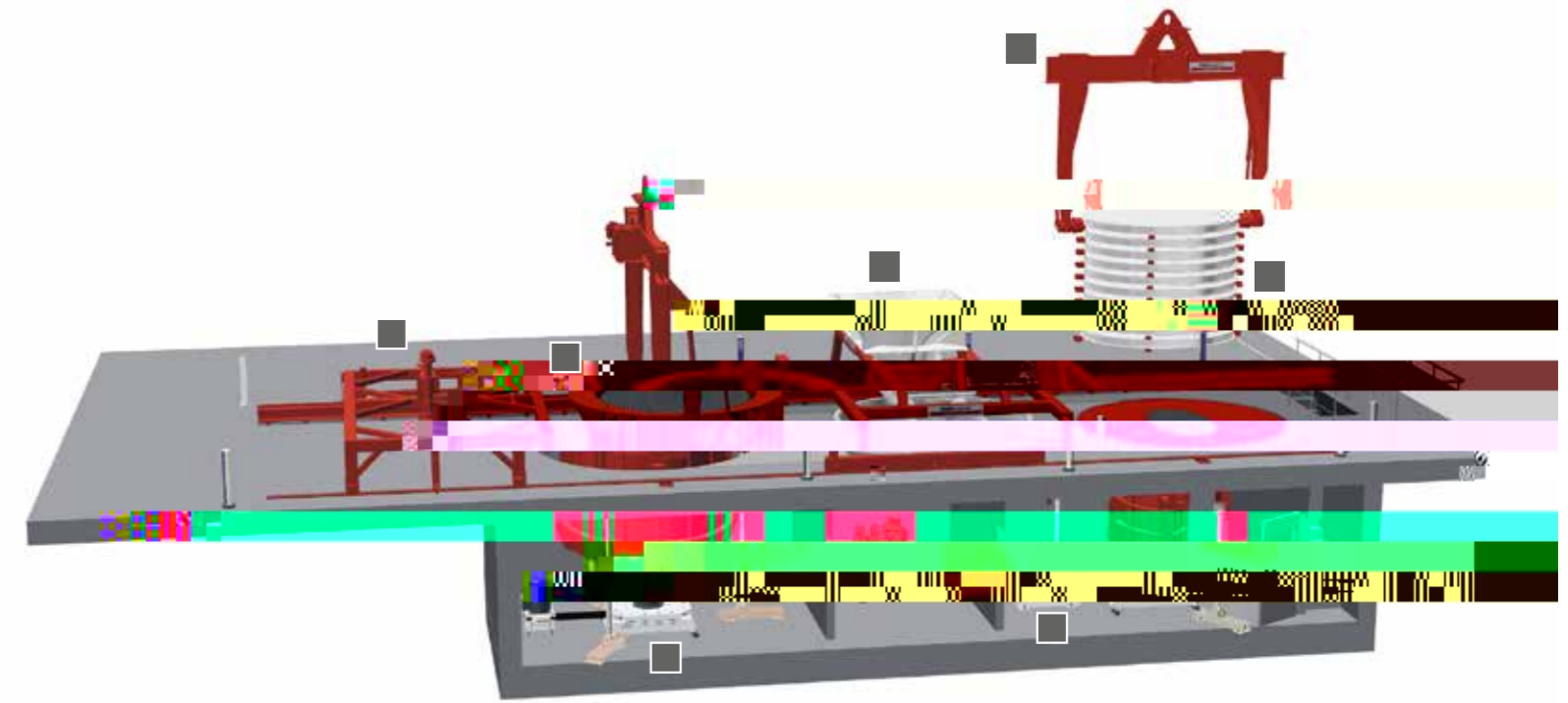

ATLAS 350/300



PRIMUSS 2.0

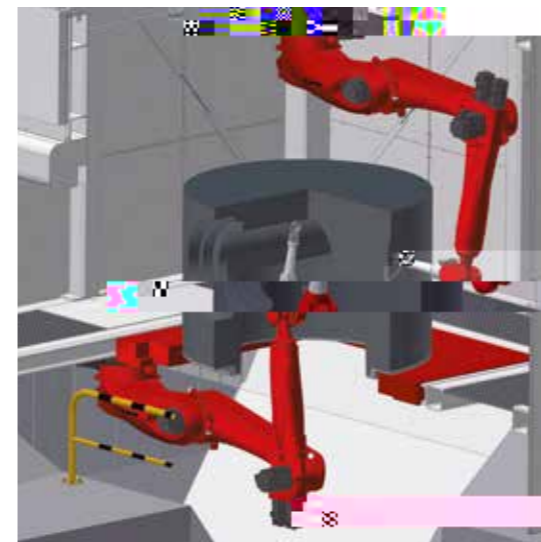
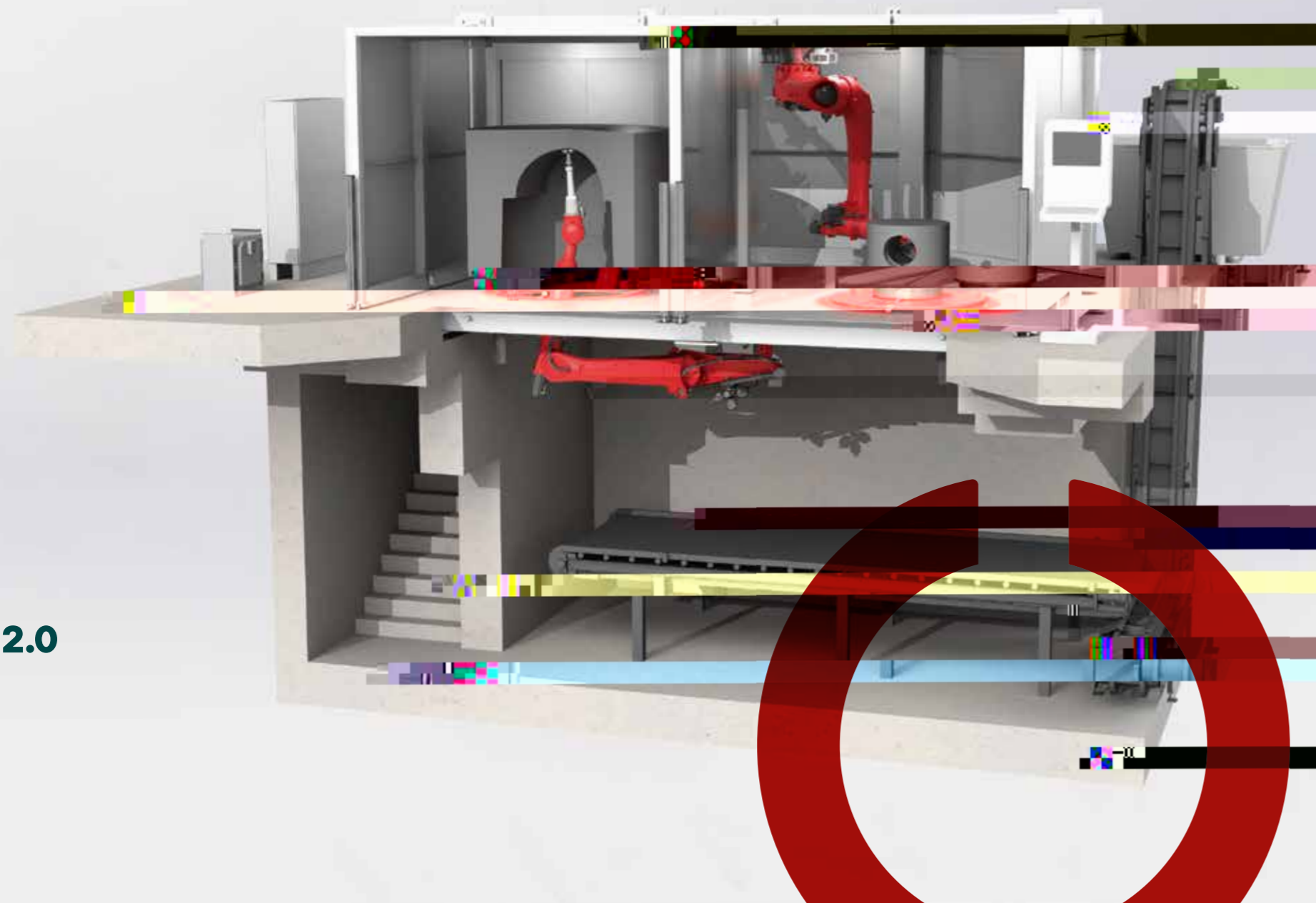

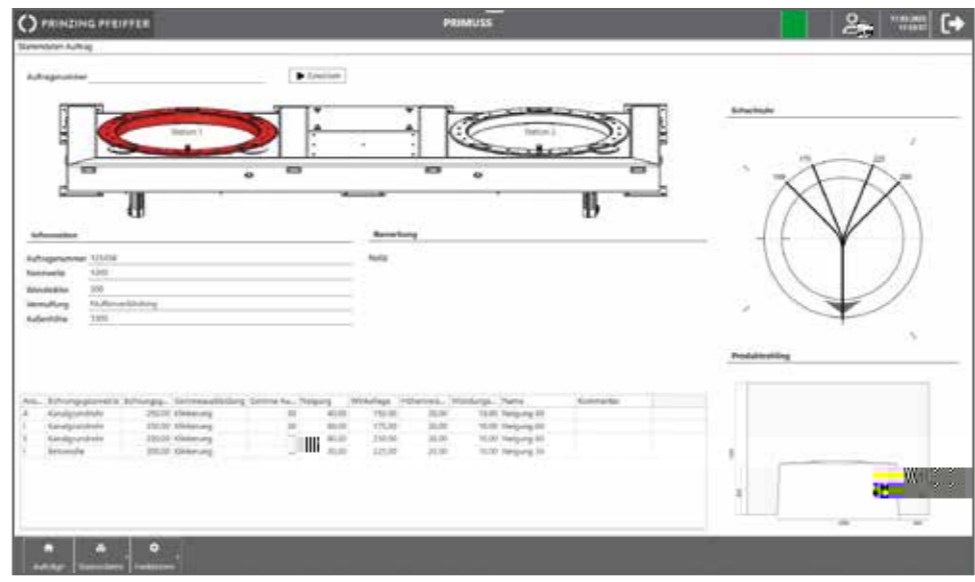

VORTEILE DER PRIMUSS-SCHACHTUNTERTEILE

-
-
-
-
-

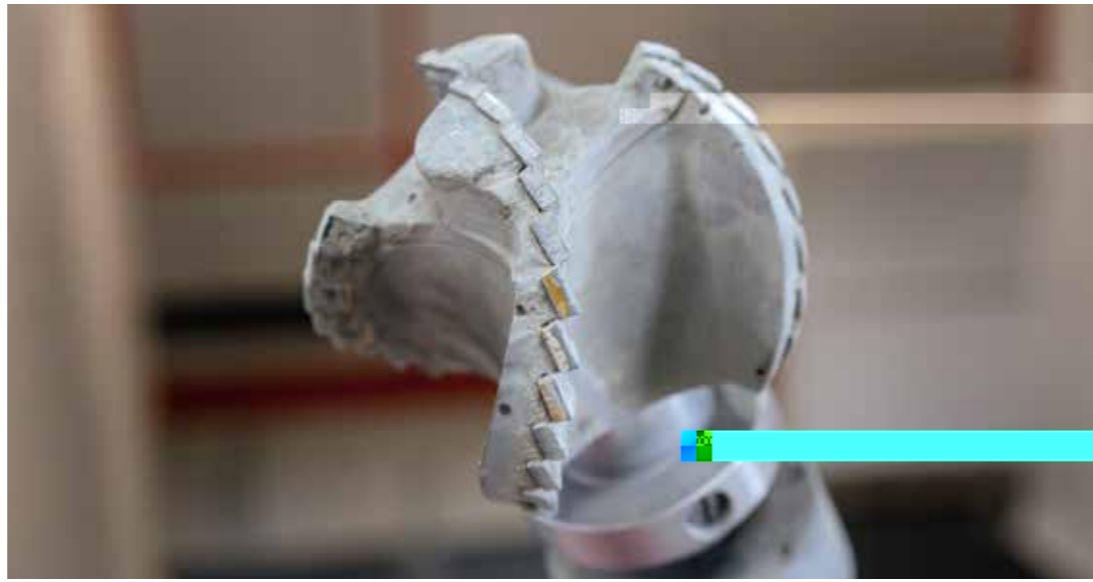
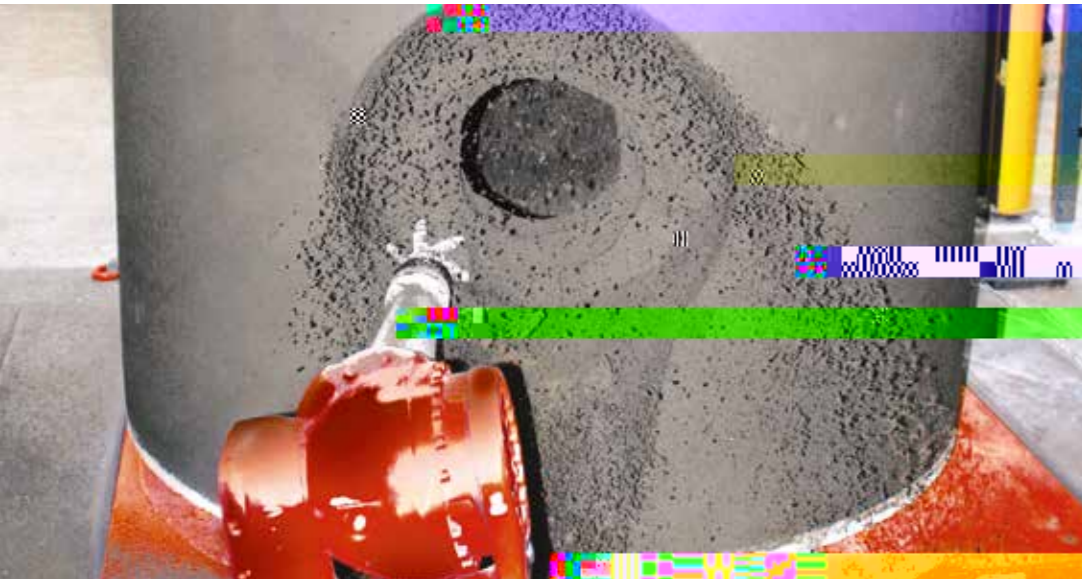

TECHNISCHE DATEN

	PRIMUSS	PRIMUSS 2.0

ERWEITERUNGSMÖGLICHKEITEN DER PRIMUSS

-
-
-
-
-
-
-



PRIMUSS

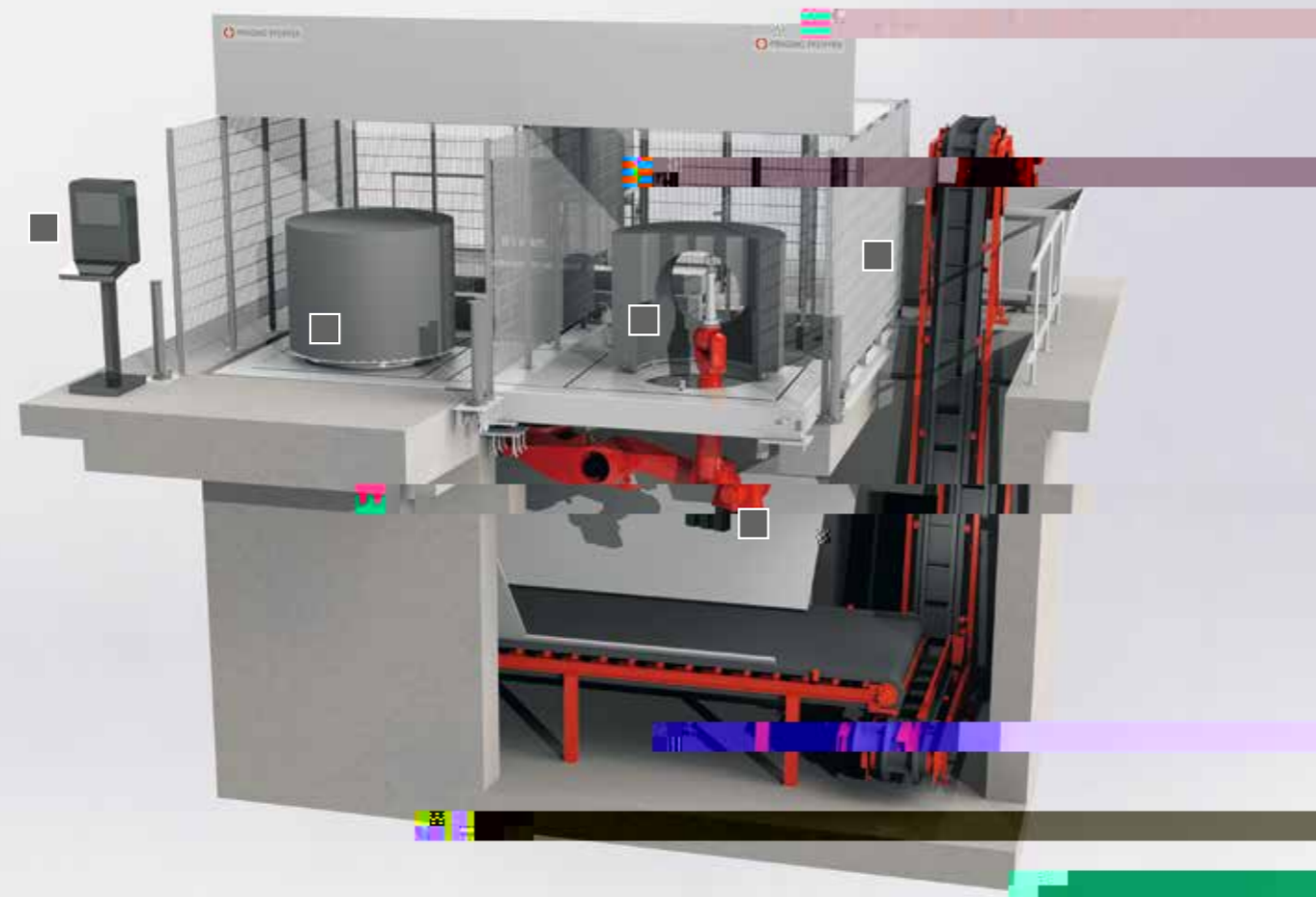

PRIMUSS

PRIMUSS 2.0

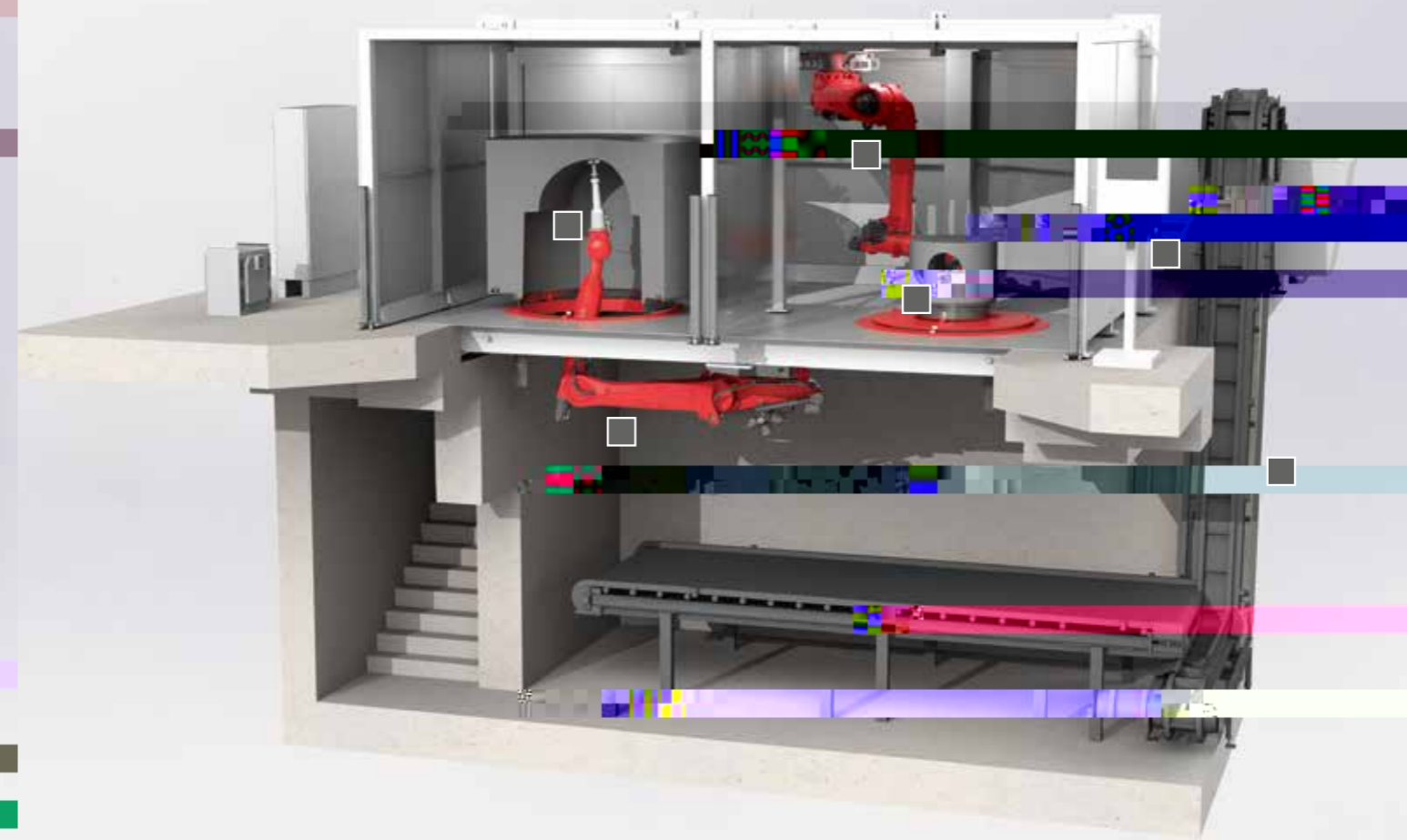

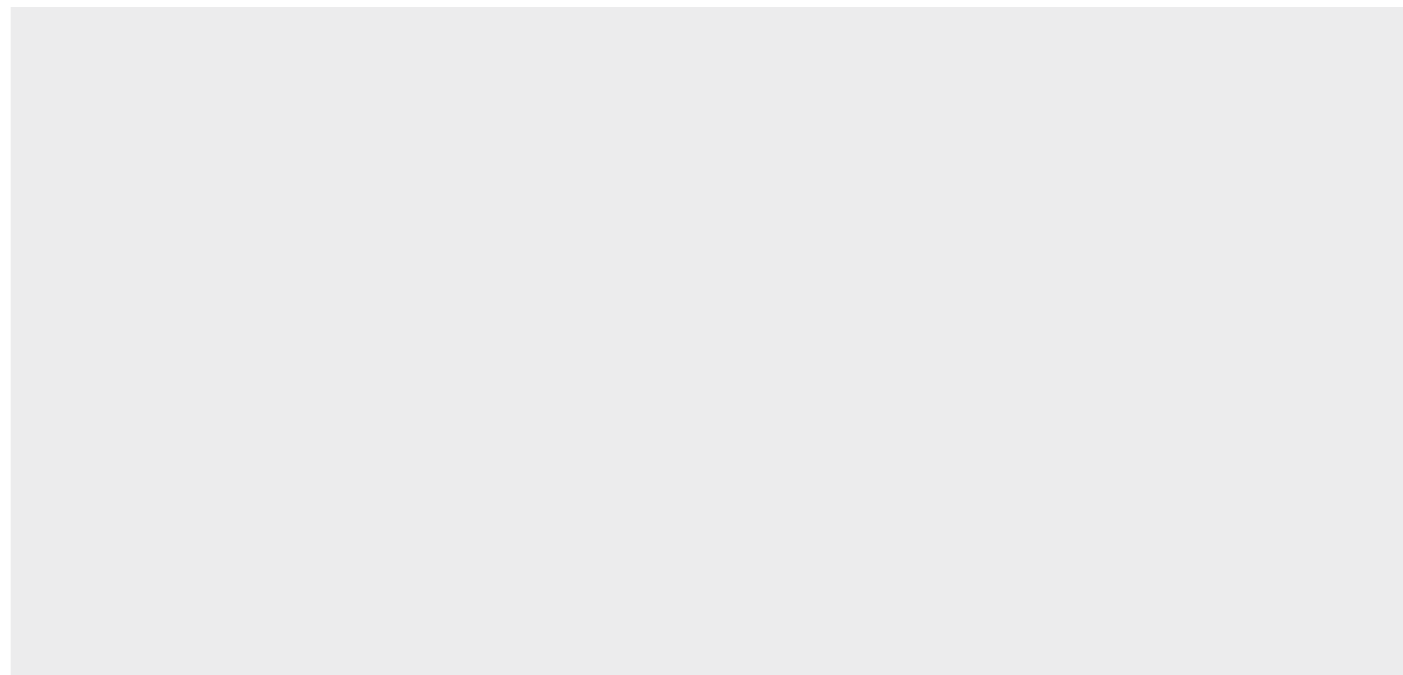
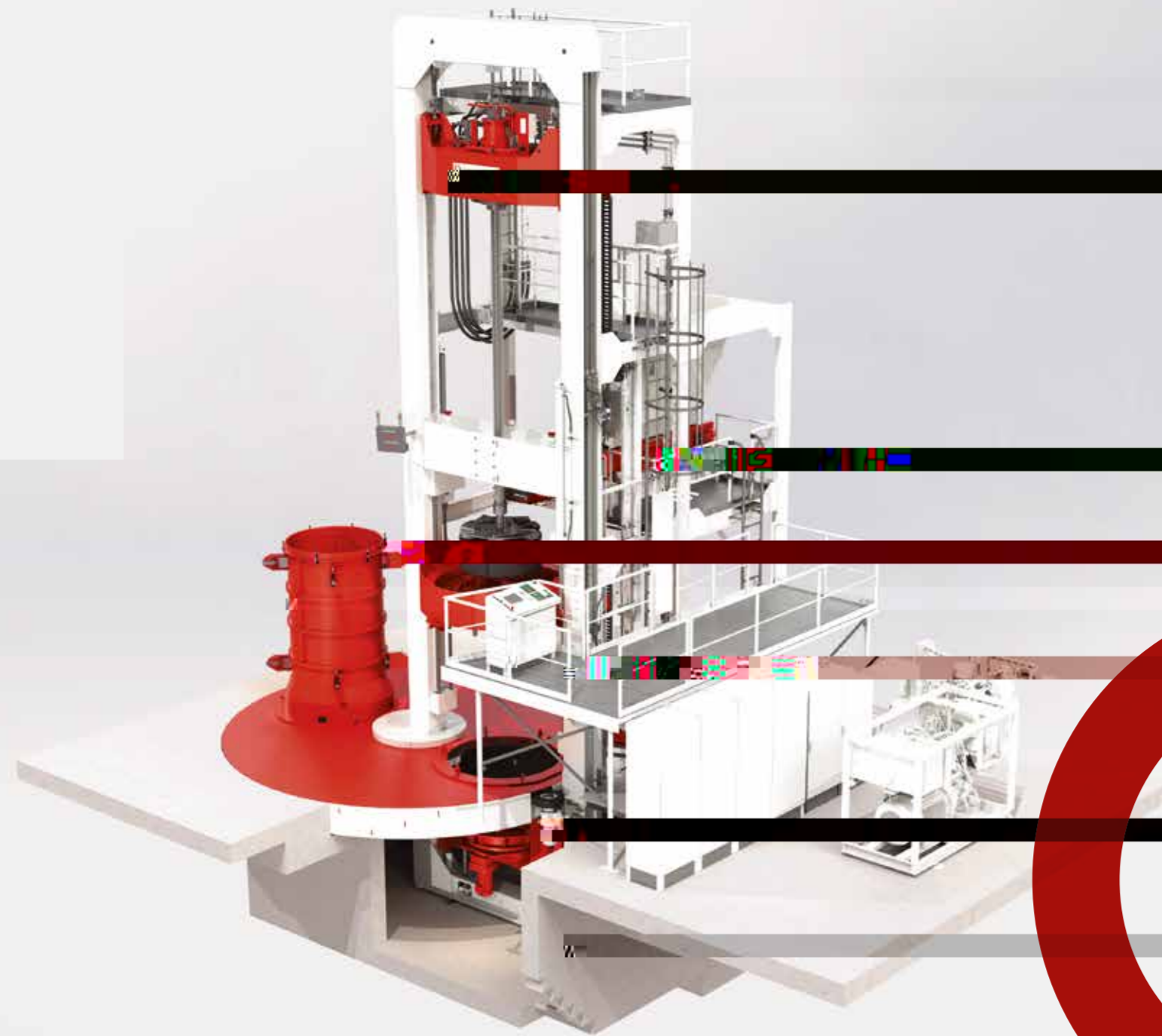



RADIALPRESSE RP 1625

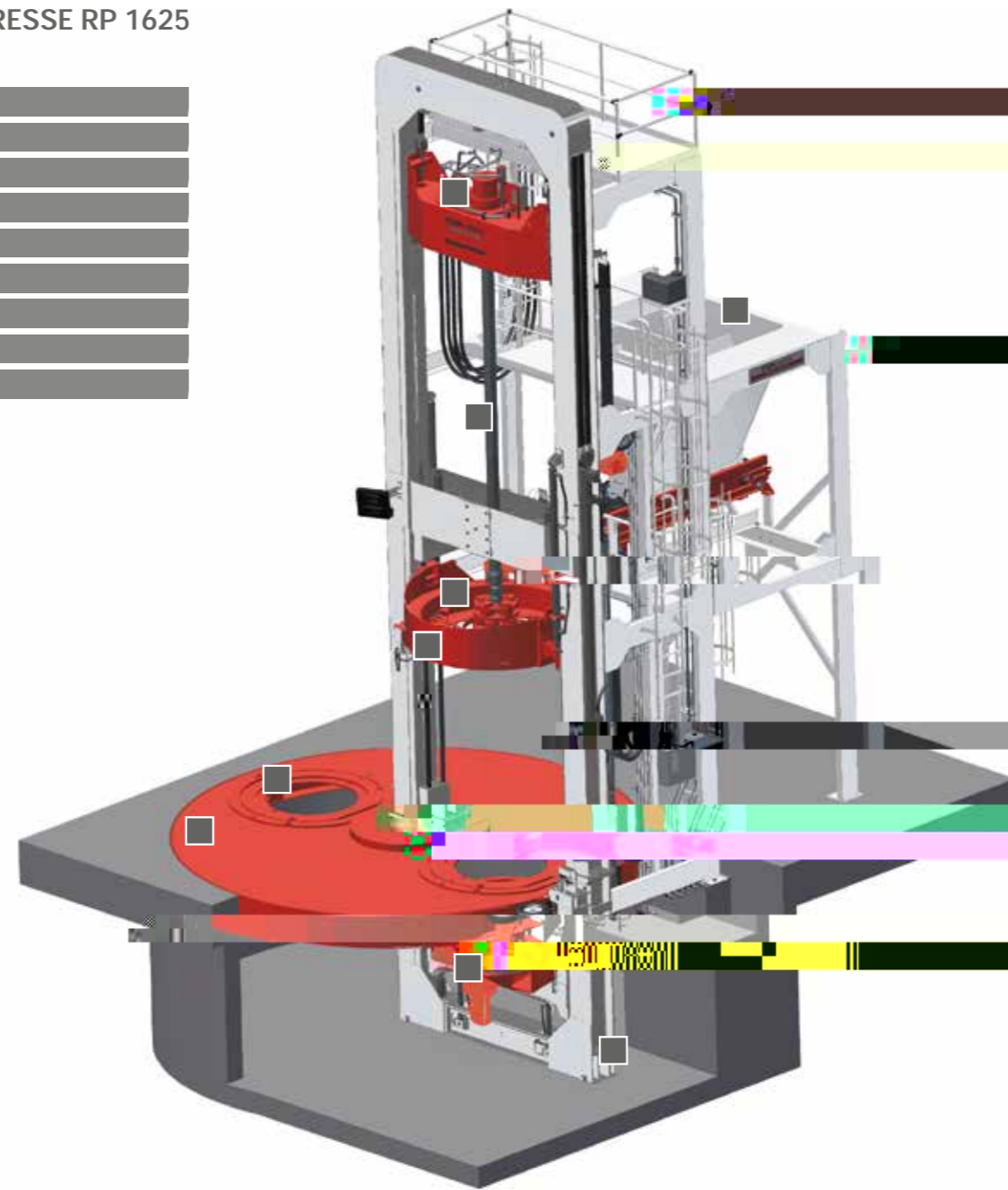

ERWEITERUNGSMÖGLICHKEITEN DER RADIALPRESSE RP

-
-
-
-
-
-
-
-
-



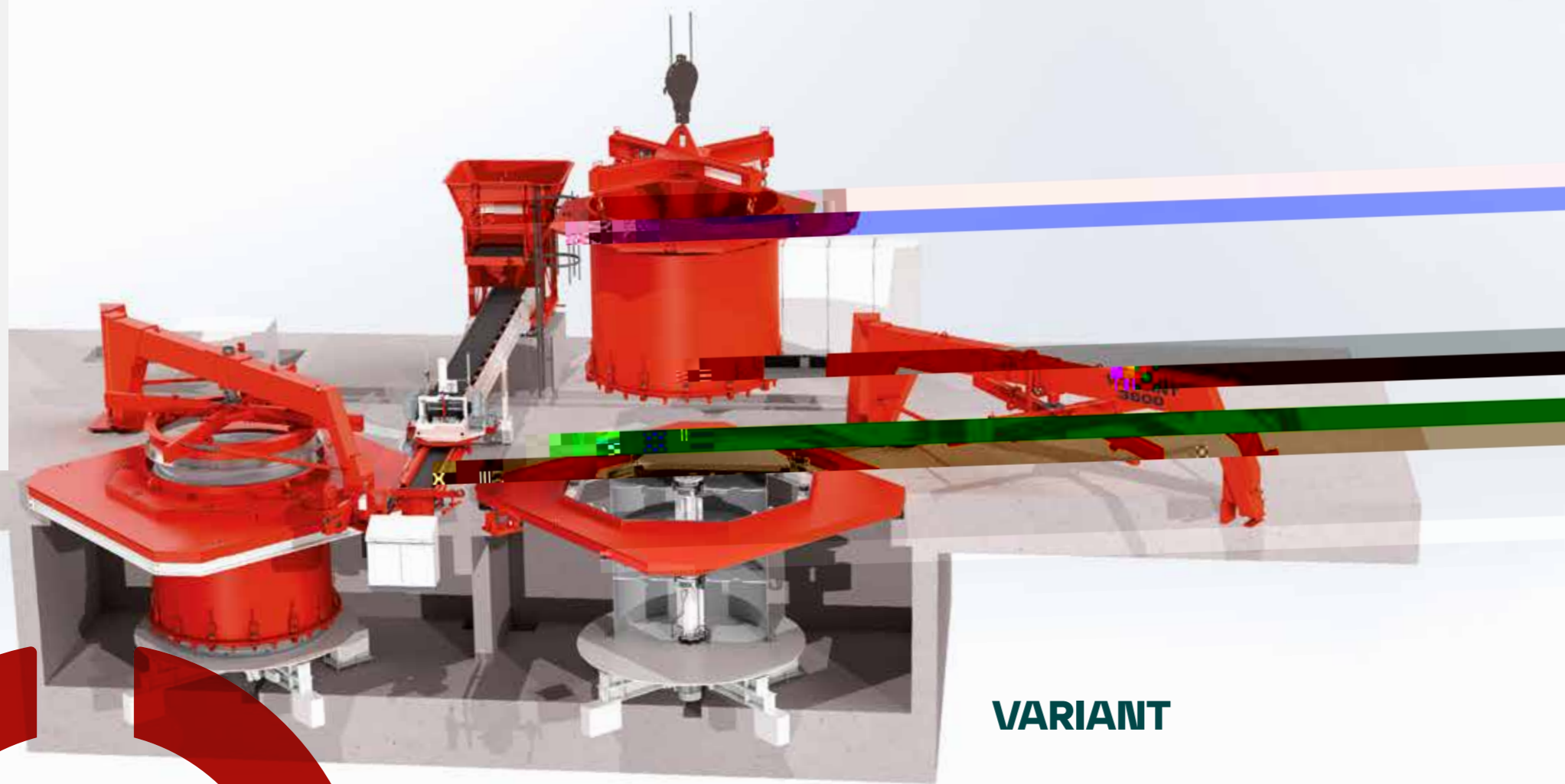

VARIANT

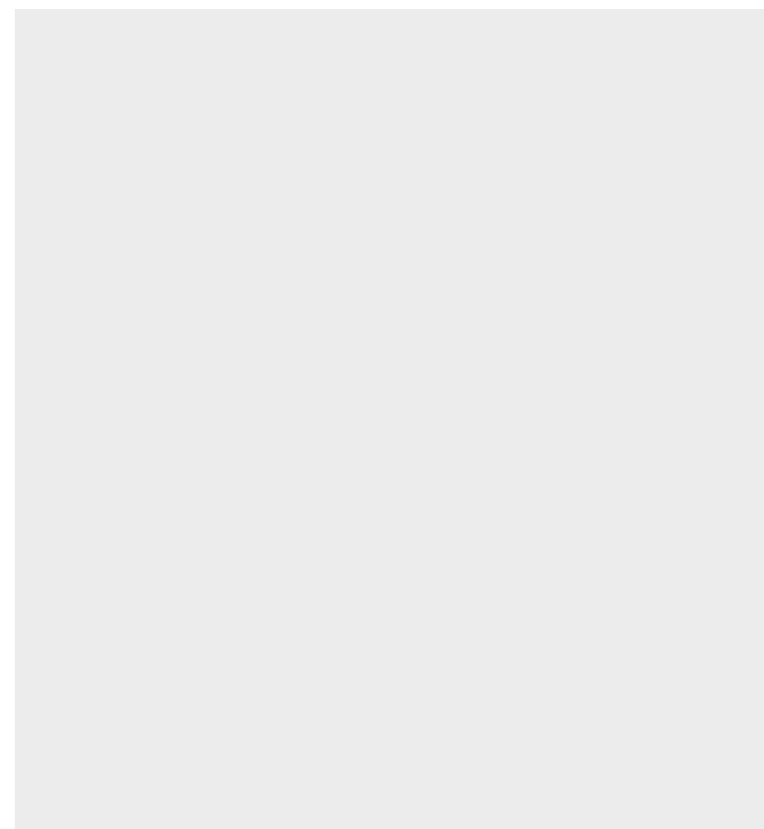
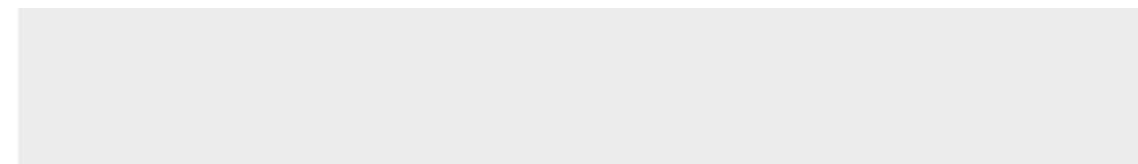
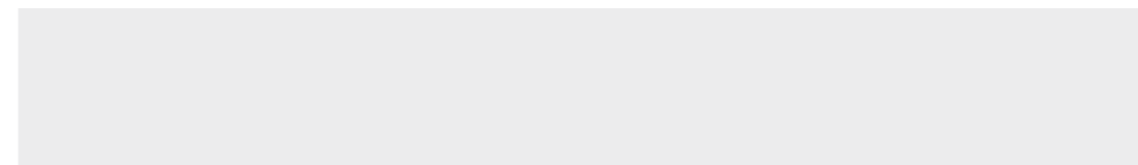
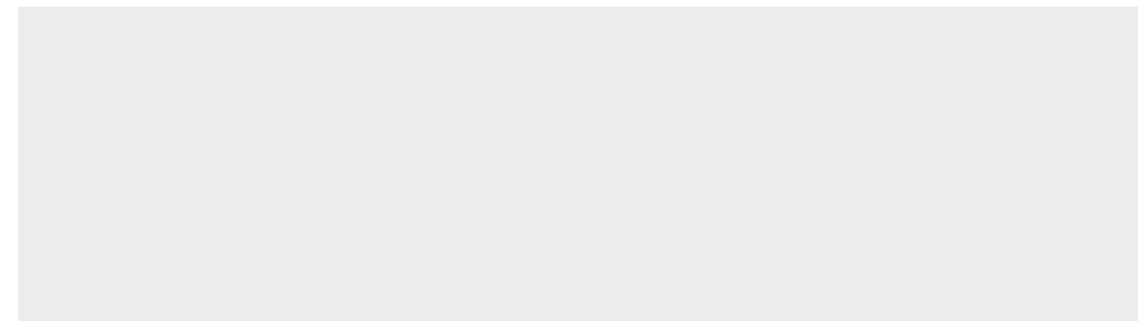



VARIANT
Produktionsanlage für Großrohre und Rahmenelemente

TECHNISCHE DATEN

VARIANT	1500	2500	3600	6000

ERWEITERUNGSMÖGLICHKEITEN
DER VARIANT

-
-
-
-
-
-
-

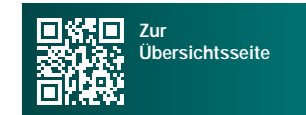
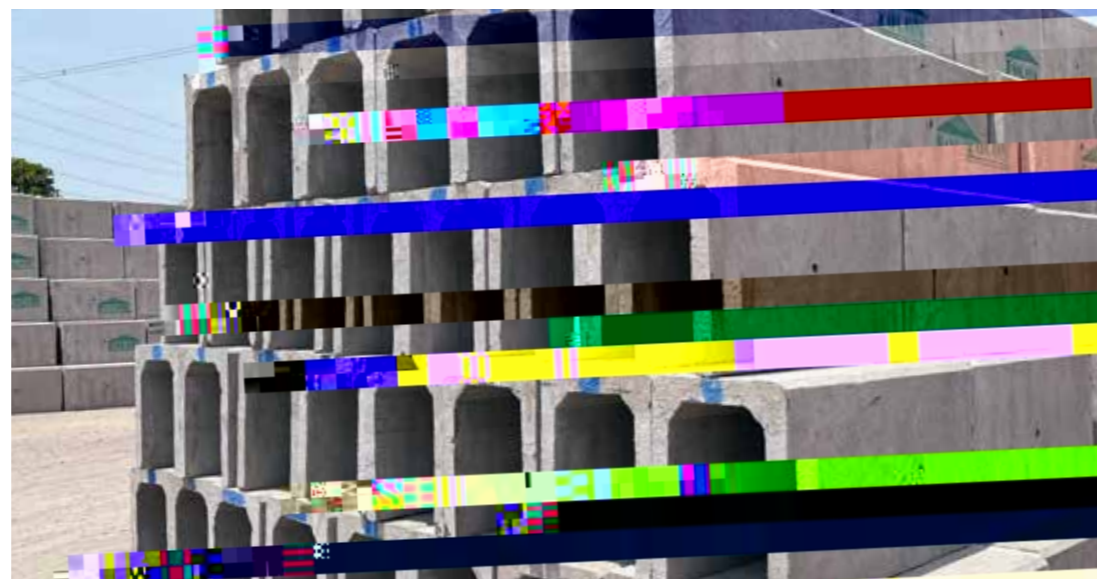

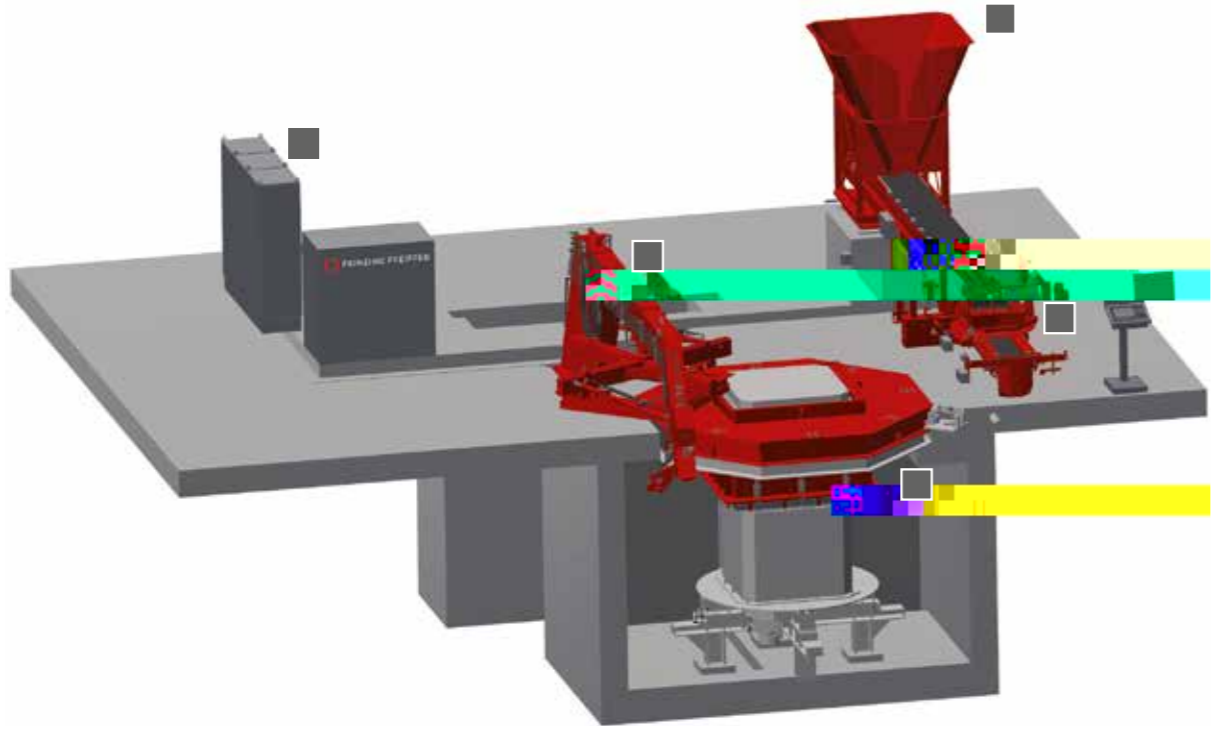

VARIANT 2500 E

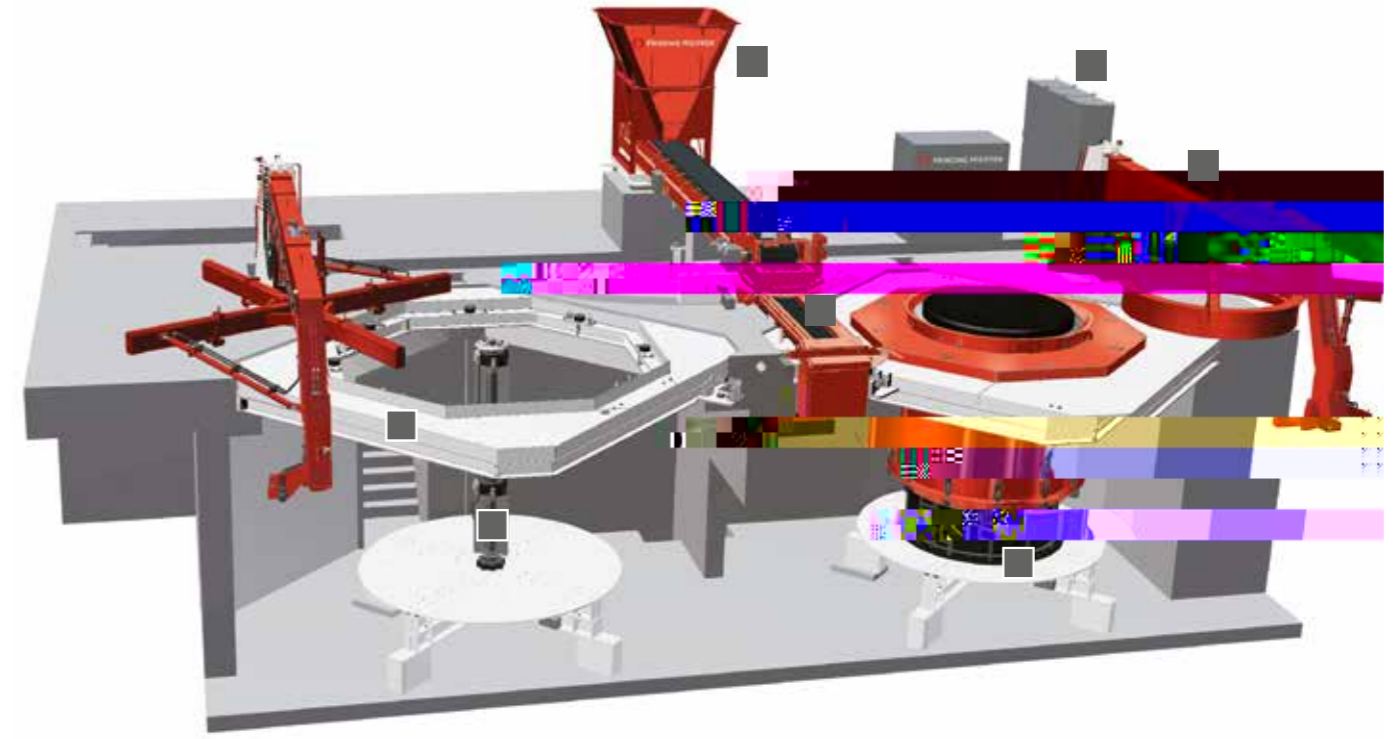

VARIANT 3600 D



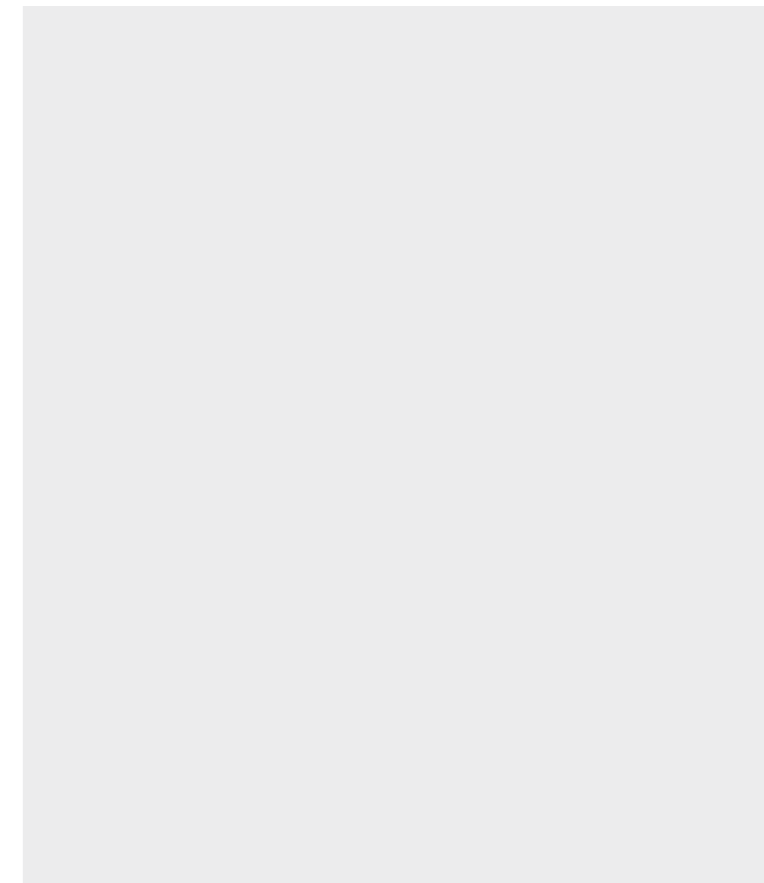
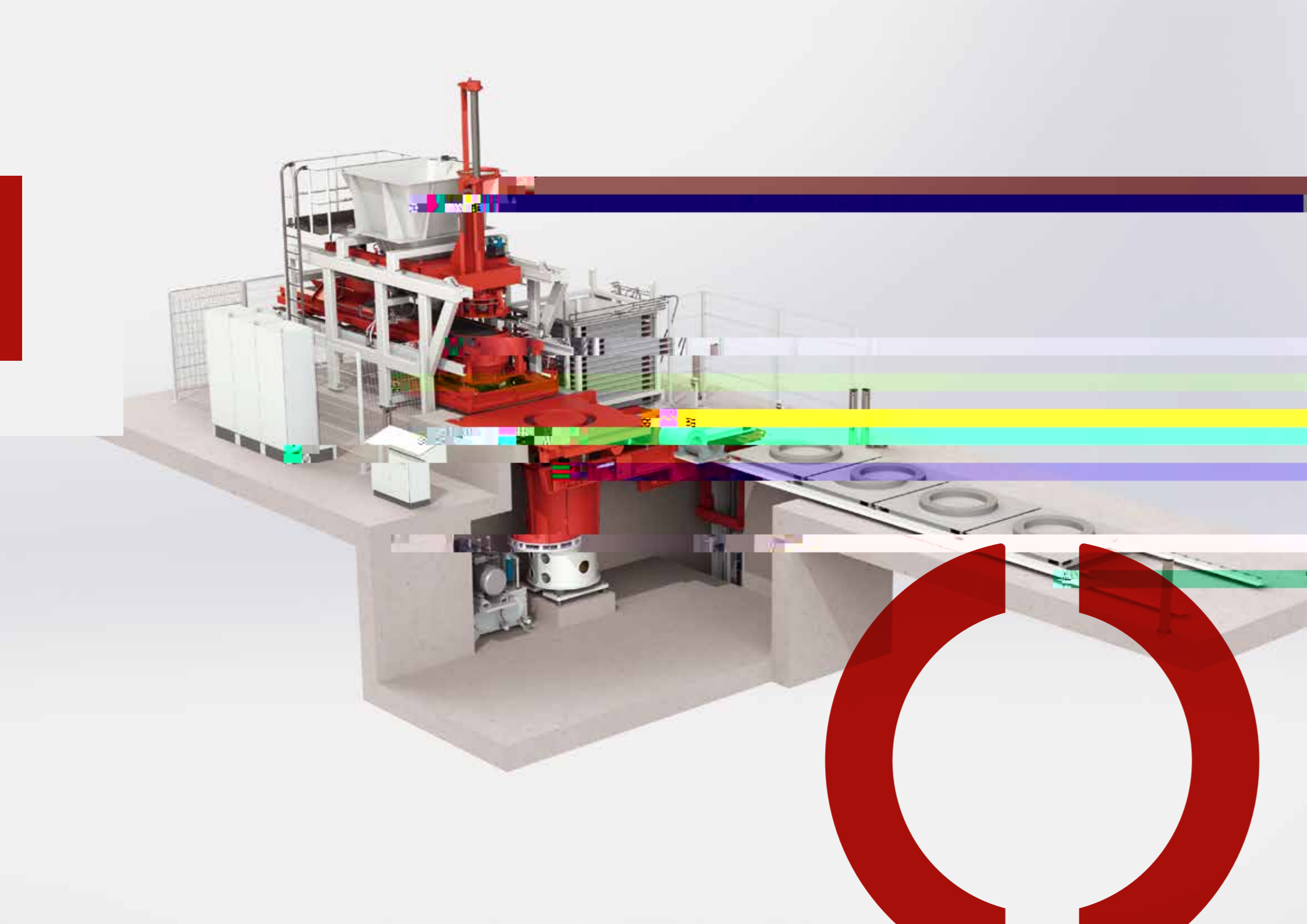

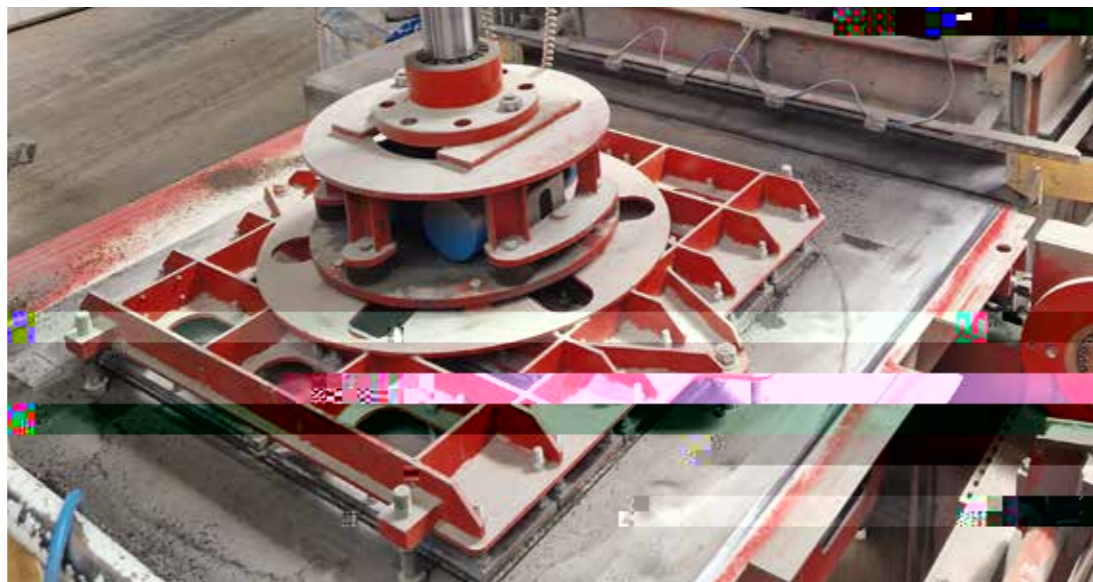

ERWEITERUNGSMÖGLICHKEITEN
DER BLIZZARD



TECHNISCHE DATEN

-
-
-
-
-
-
-
-



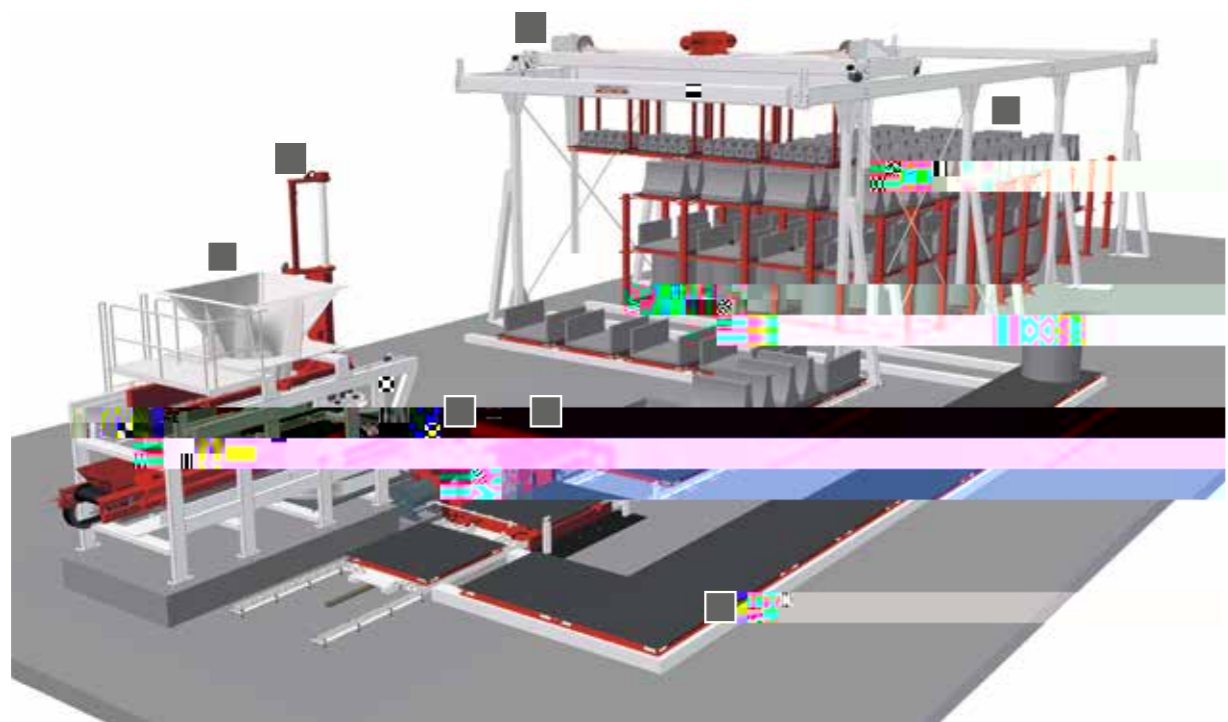

BLIZZARD 180/150

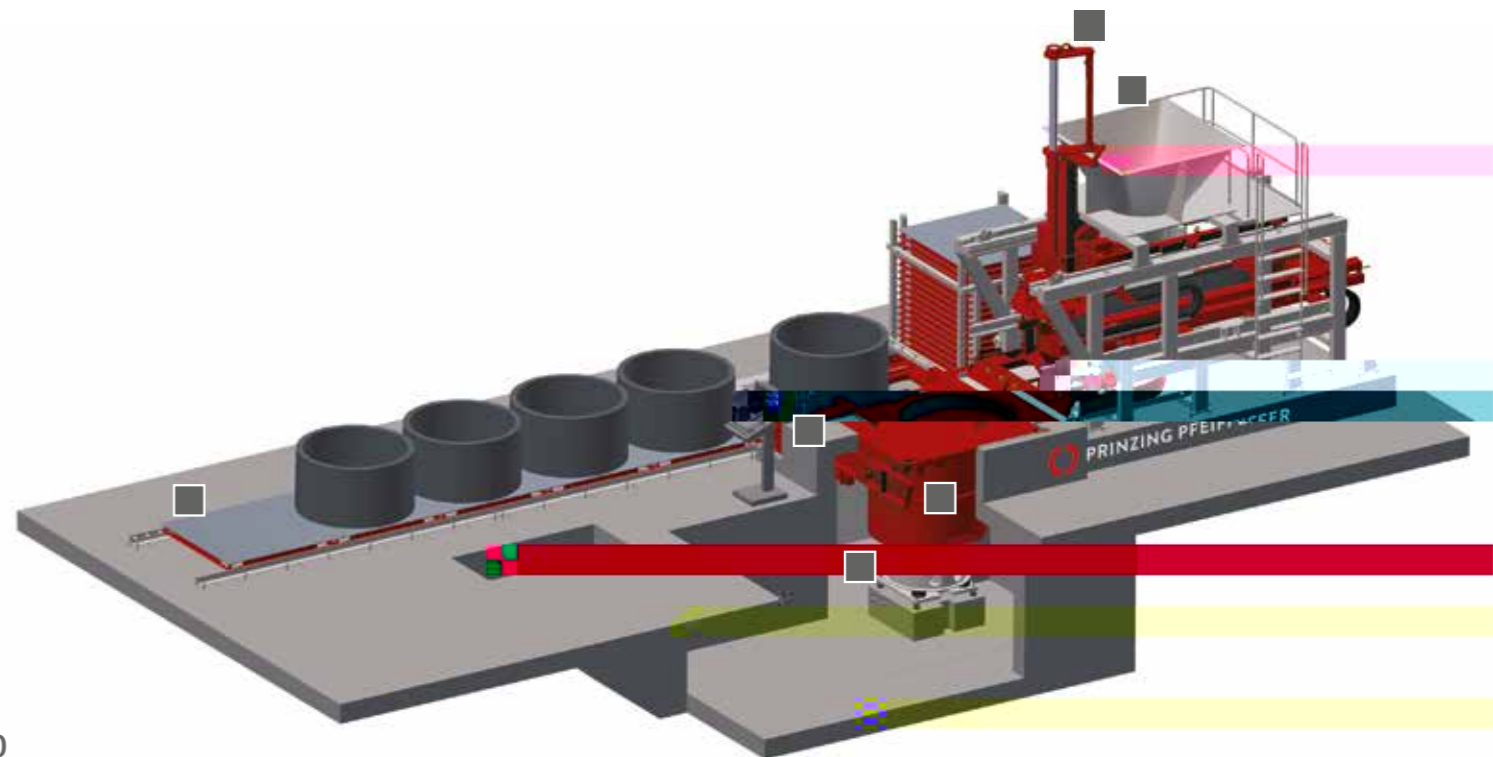

BLIZZARD 180/150



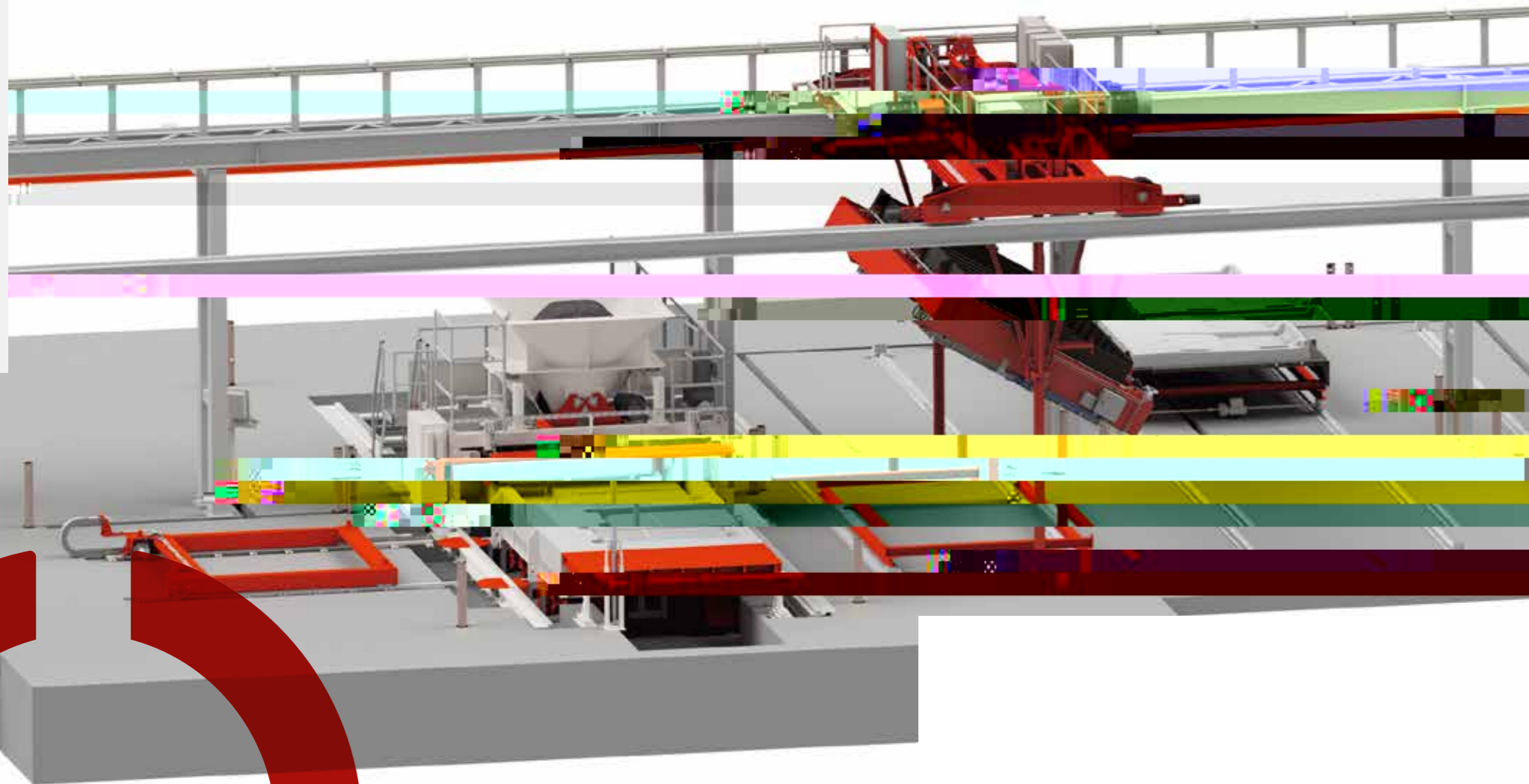

Bestens geeignet ist die ZELUS

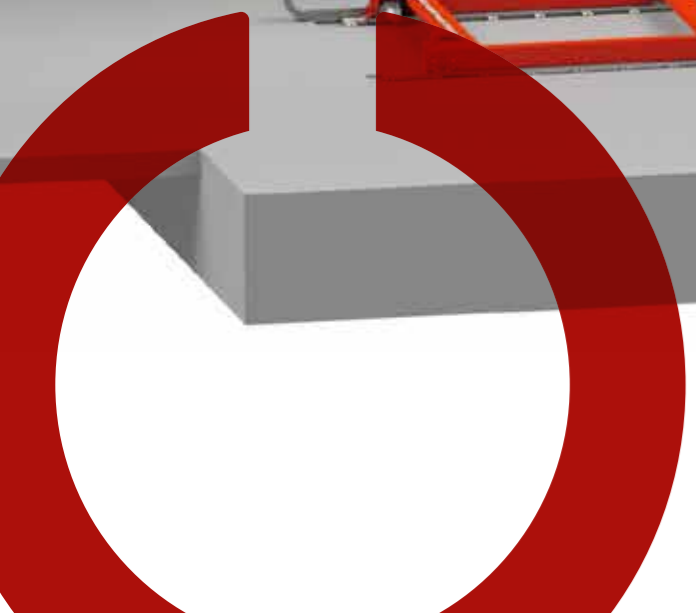
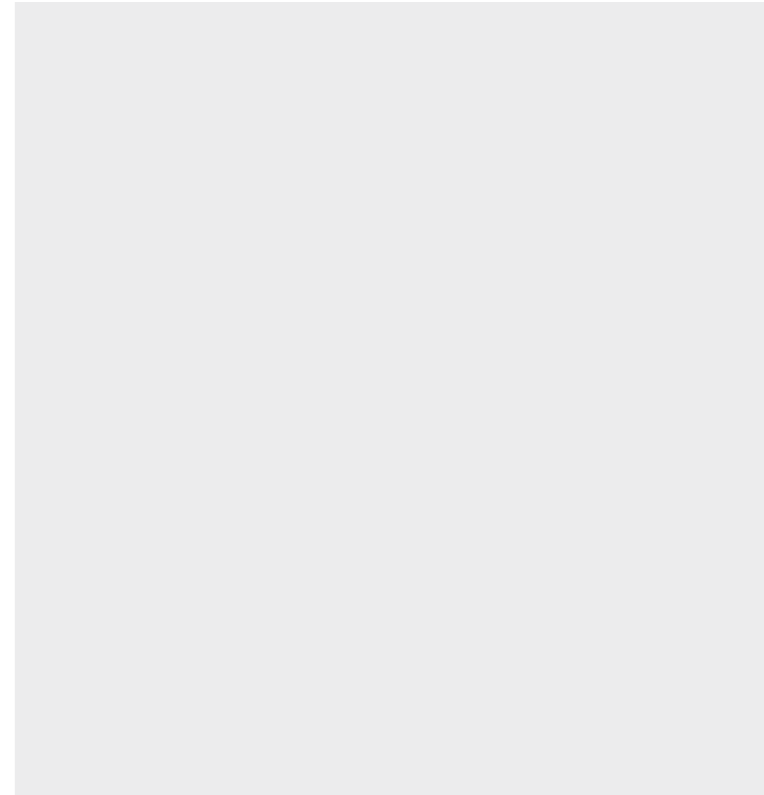
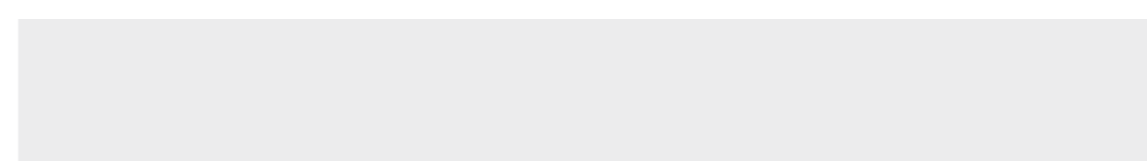
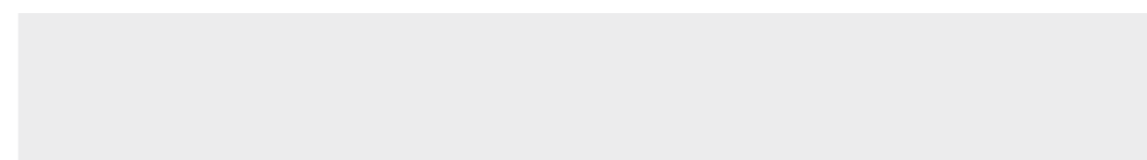
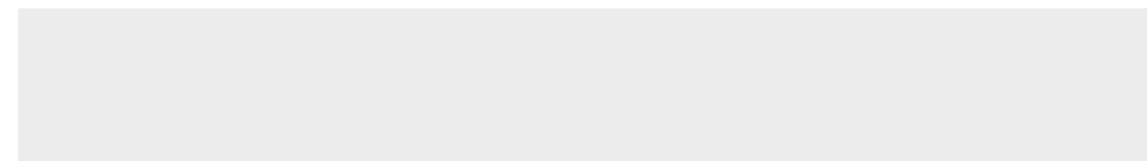
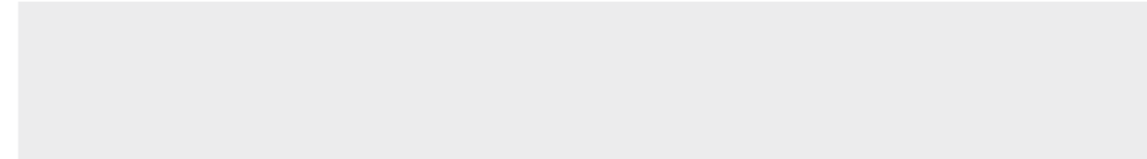
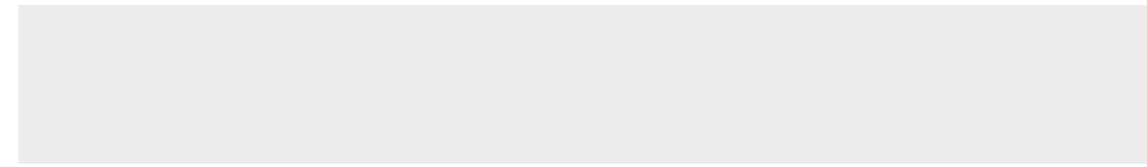

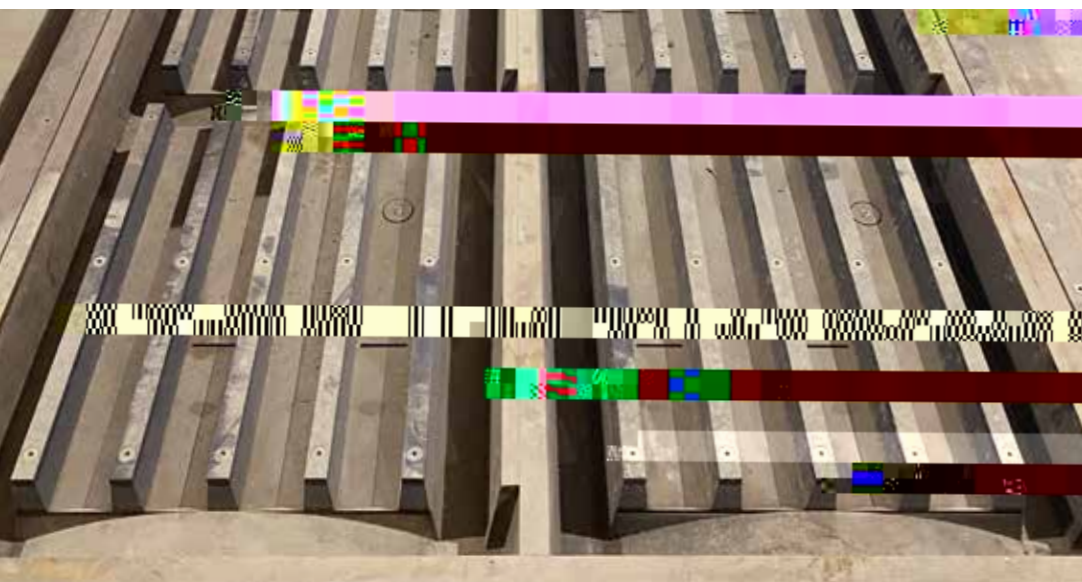
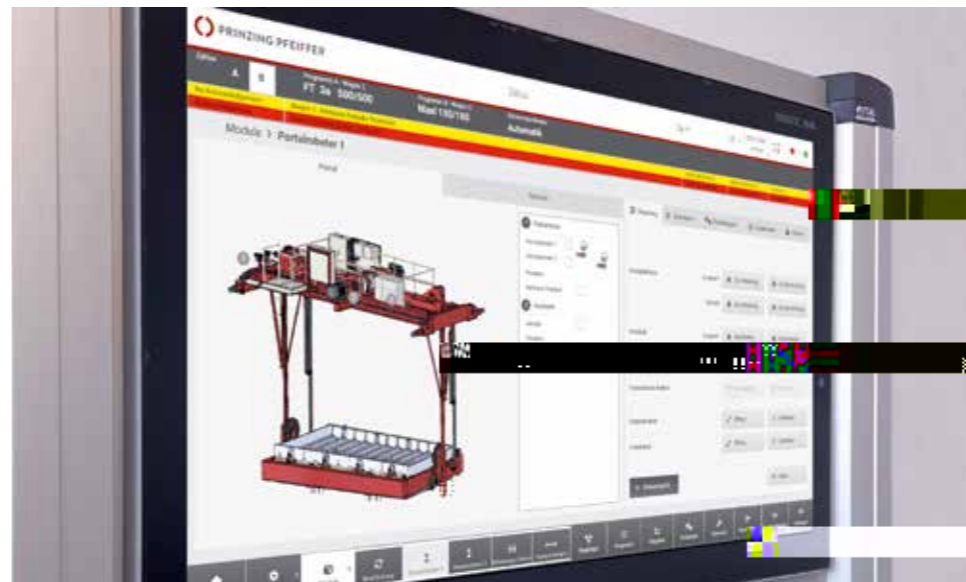

TECHNISCHE DATEN

ZELUS	400/25	500/20	600/30

ERWEITERUNGSMÖGLICHKEITEN DER ZELUS

-
-
-
-
-
-



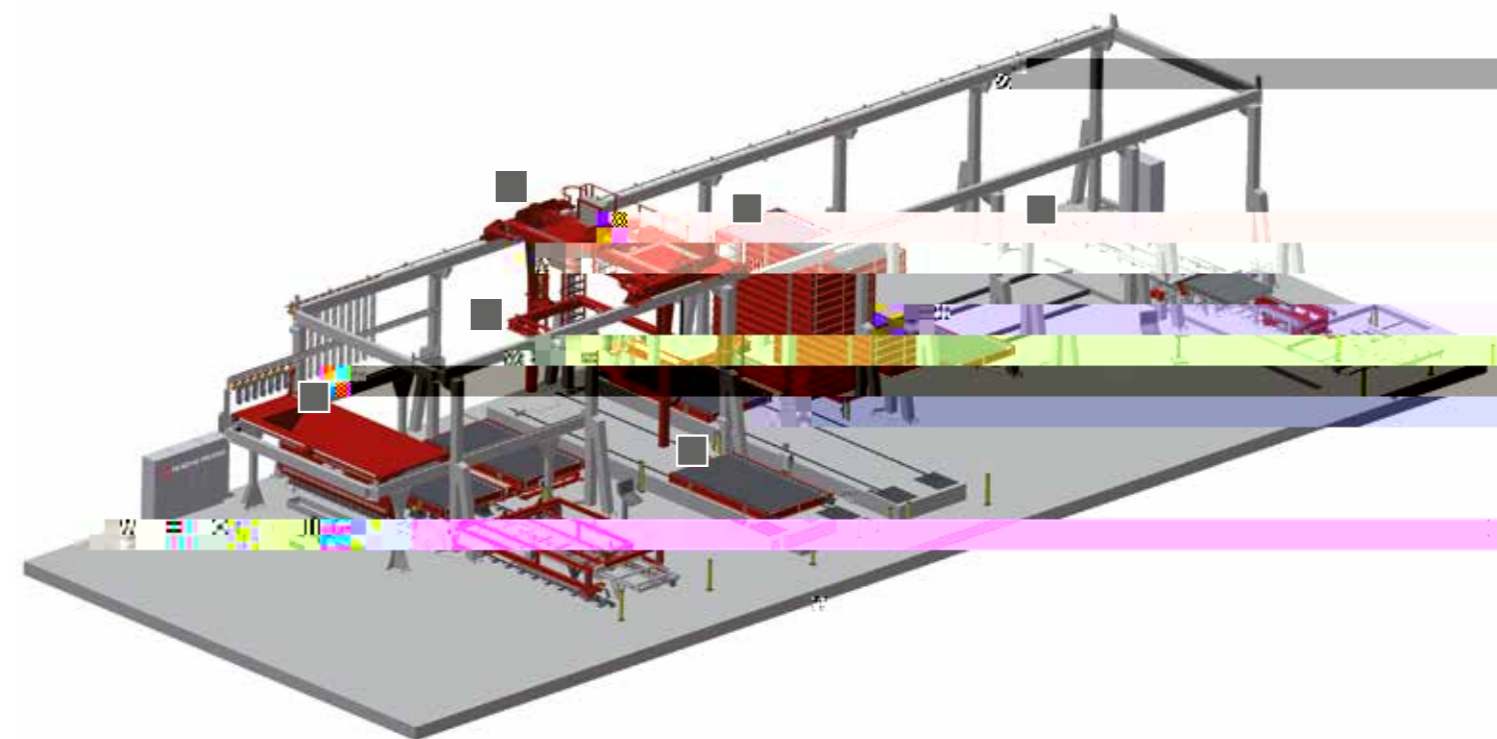
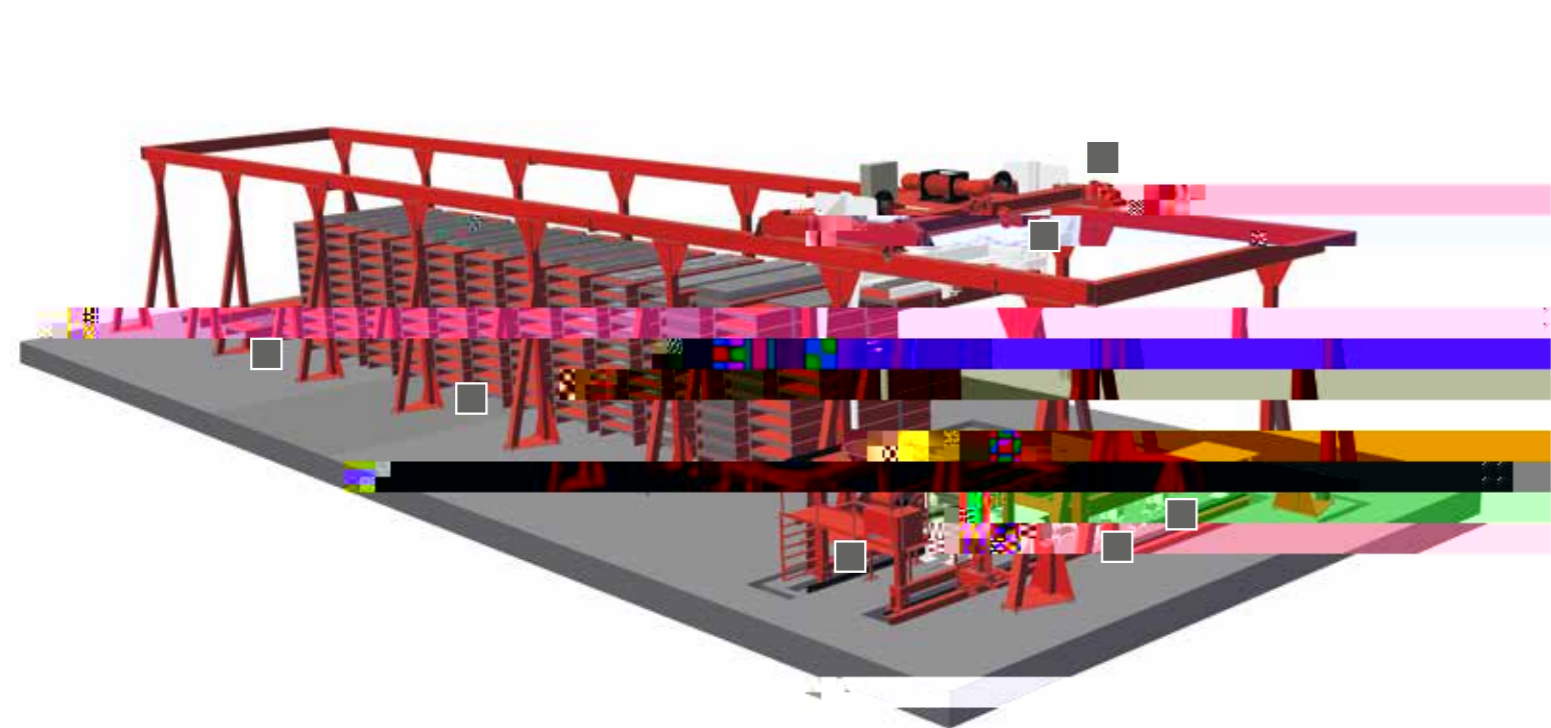



MASSGESCHNEIDERTE LÖSUNGEN AUS EINER HAND

IHR PLUS –
FORMEN UND SCHALUNGEN

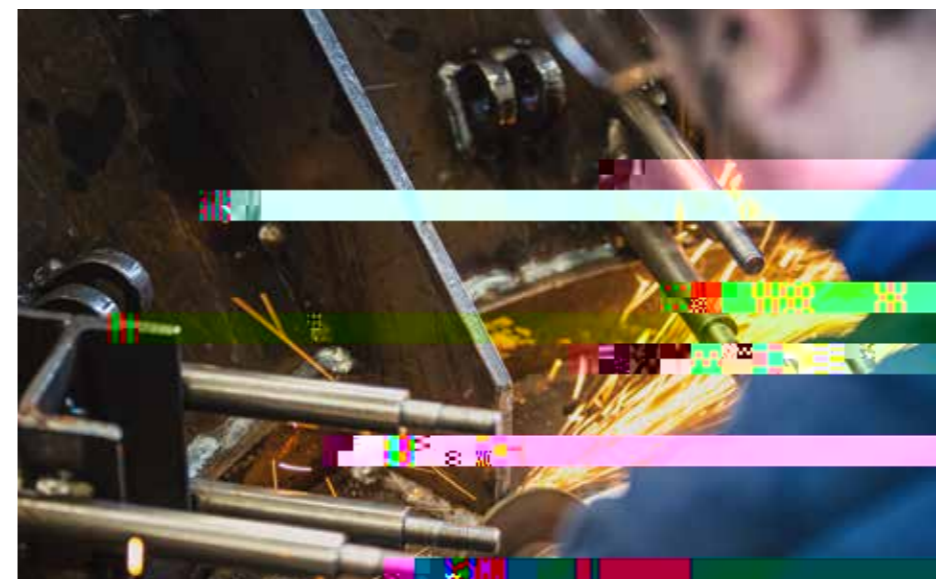

FORMEN &

IHR PLUS – HANDLING

FÜR UNTERMUFFEN UND PALETTEN

VORTEILE UNSERER HANDLING-SYSTEME FÜR UNTERMUFFEN UND PALETTEN:

-
-
-
-
-
-
-
-

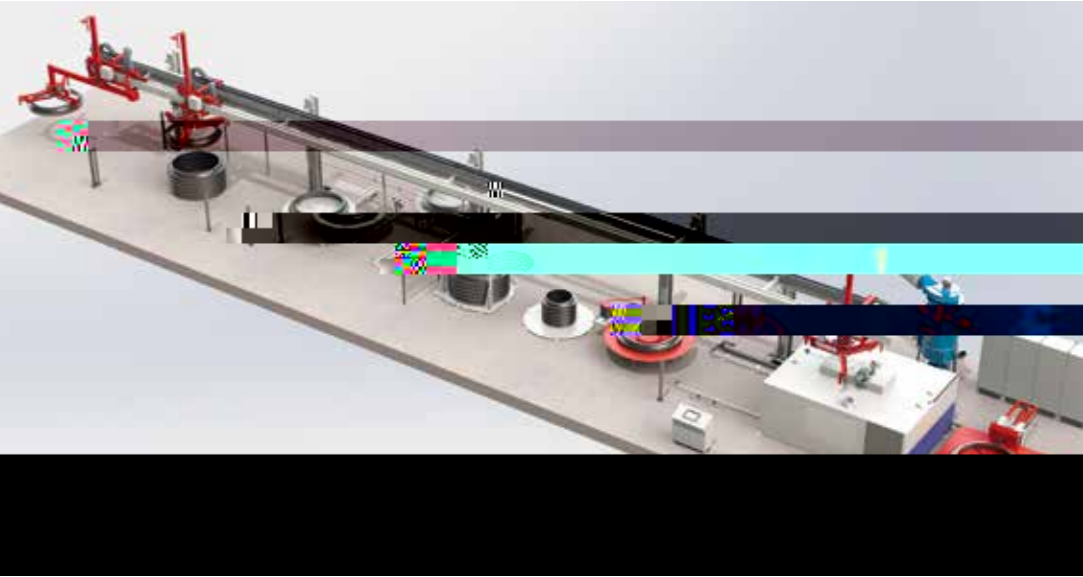
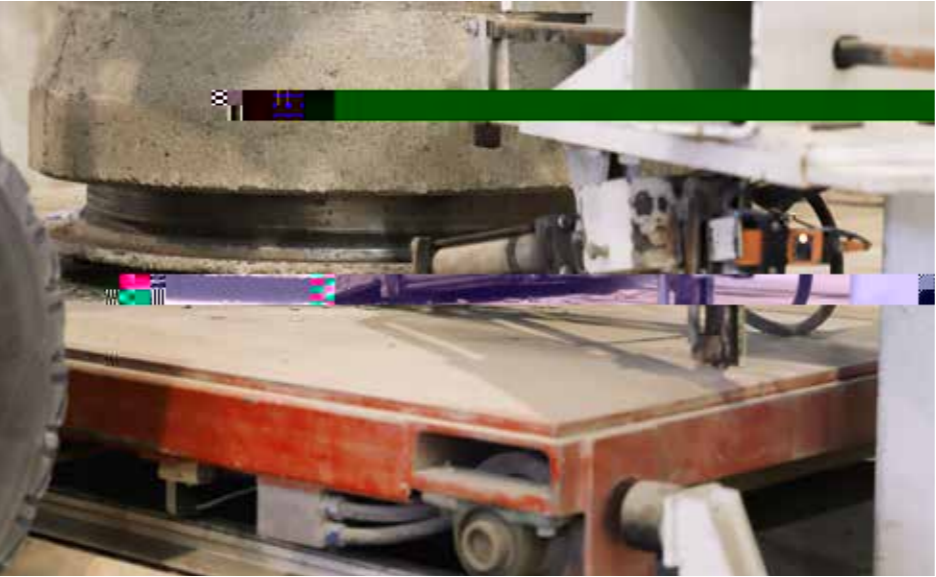
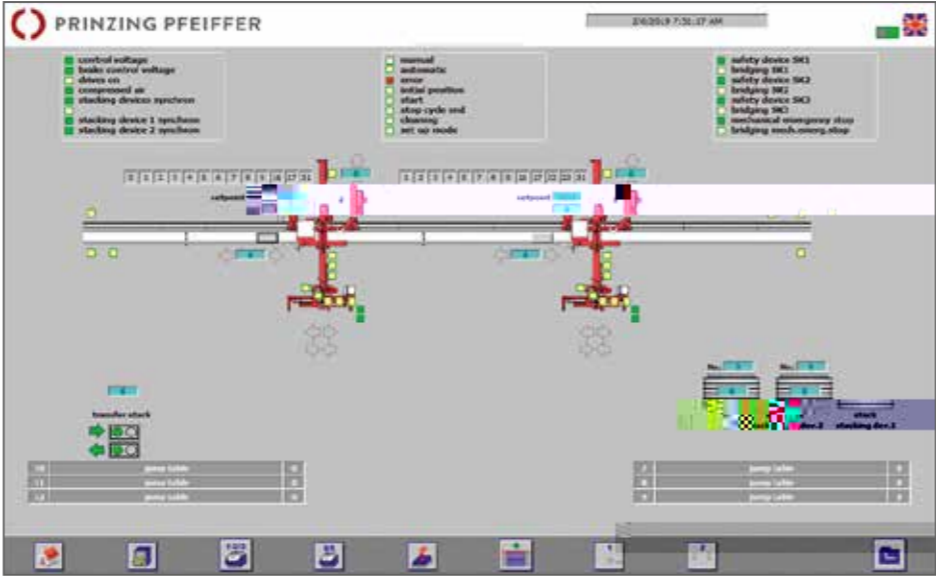
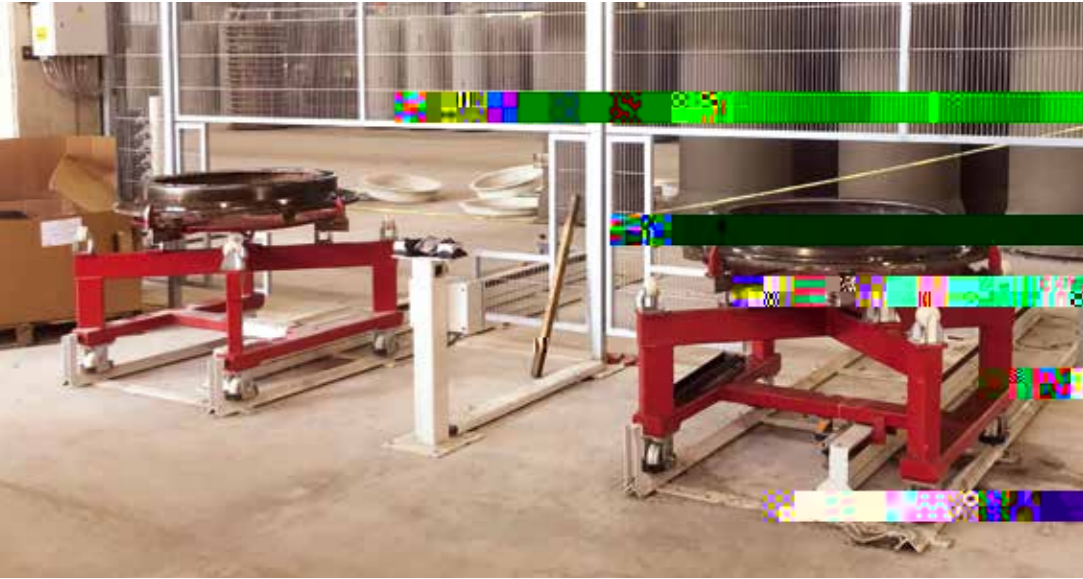
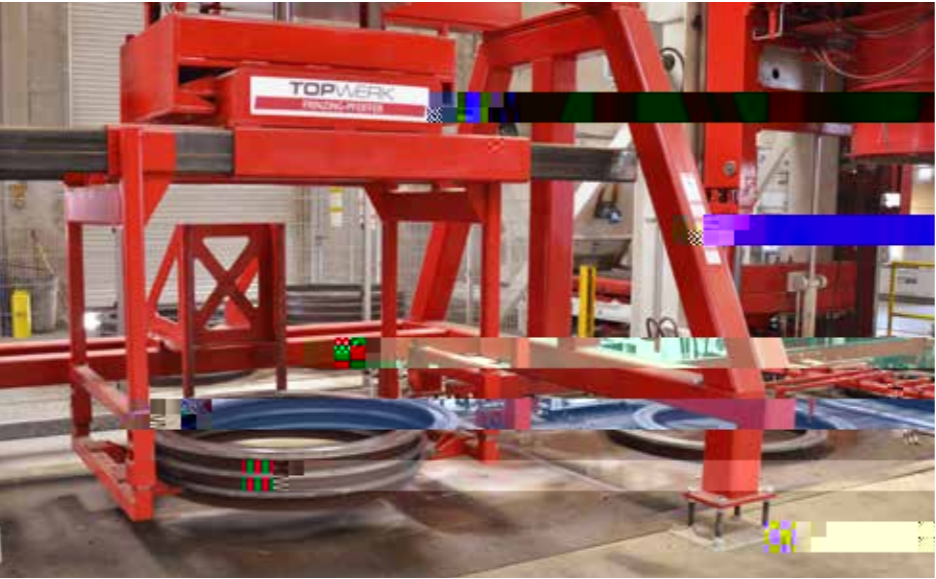

IHR PLUS – PRODUKTIONS- UND FIRMIENSTÄNDE

INHOUSE-FERTIGUNG, VERTRIEB, ENGINEERING,
AFTER SALES





AUTOMATISIERUNG

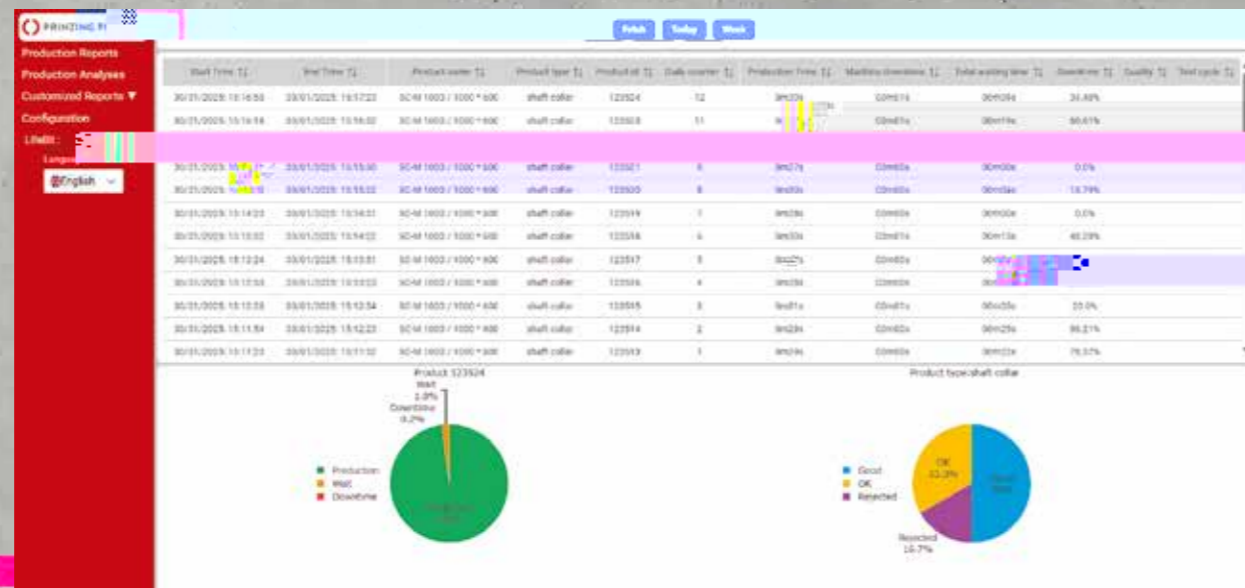
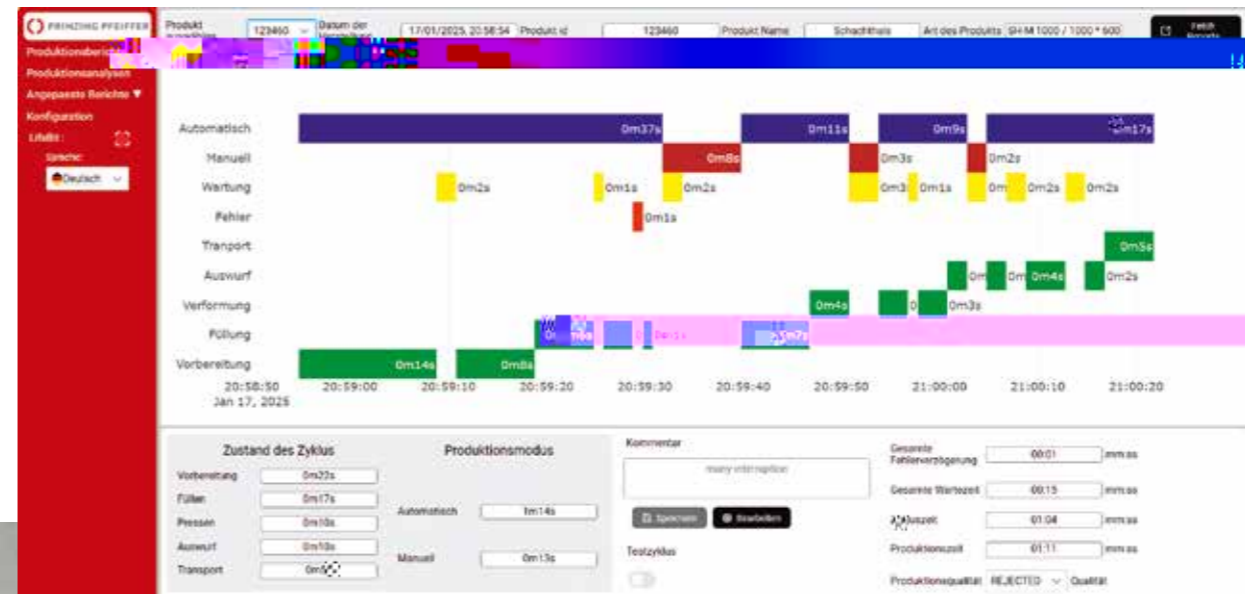

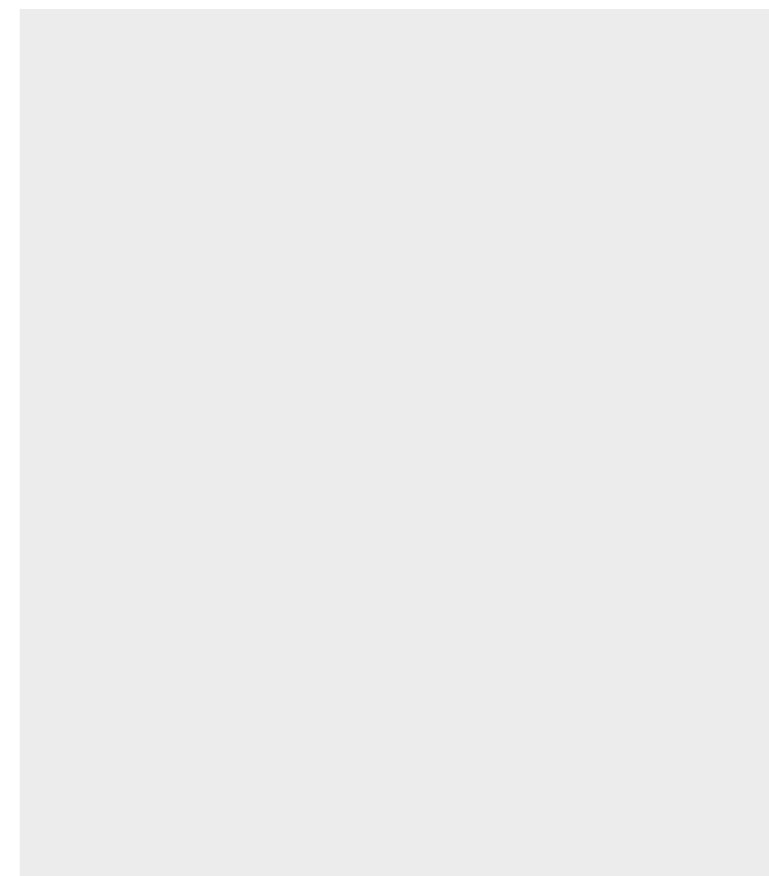
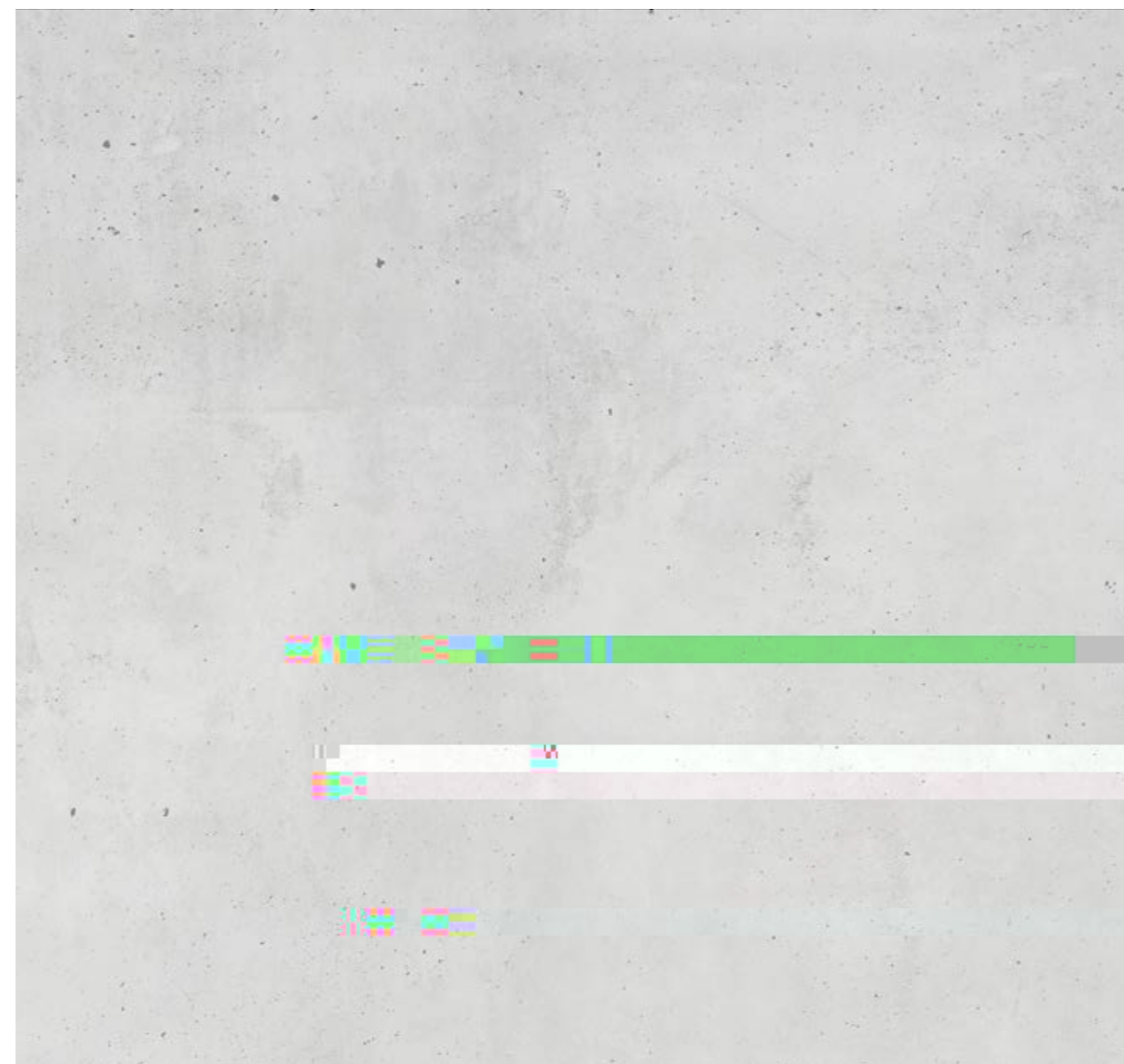



AFTER SALES

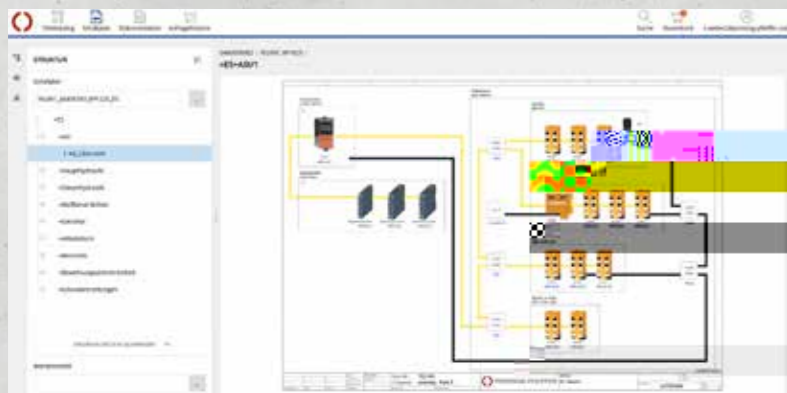

MR X M Z I R 7 G L P X T ž R I R Q P p Ā X H M I - H I R X M ¼ ^ M I V Y R K Q Y G L P] W G L Y V Y R H I P I O D r i s c h e r i l b n l a g e i n f a c h e r d e n n i D a m i t d e n D E r s a t z t e i l a n f r i a g n o n l i n e a n u n s ü b e r m i t t e l t u n d 0.9 (i s e) 019 (i b e k o m m

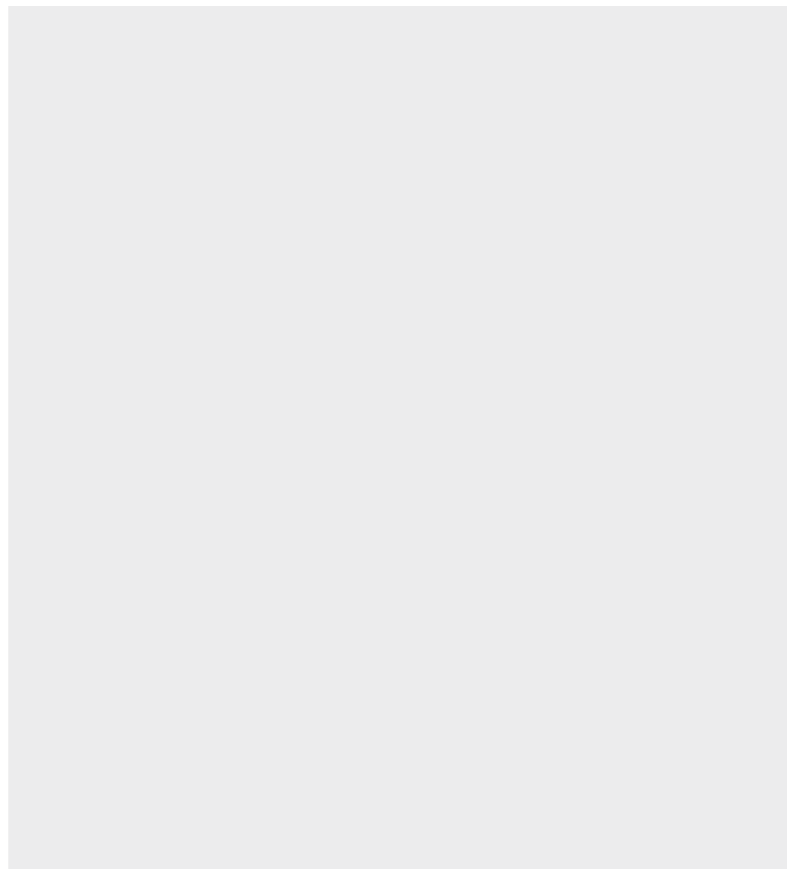

ALLES AUS EINER HAND



VERTRIEBSTEAM



Björn Brandt



Andreas Bartuli



Alexander Probst



Reda Guessous



Thomas Linnert



Thiago Leao



Jan Nemitz



P

