

HESS GROUP

A member of TOPWERK

HESS GROUP

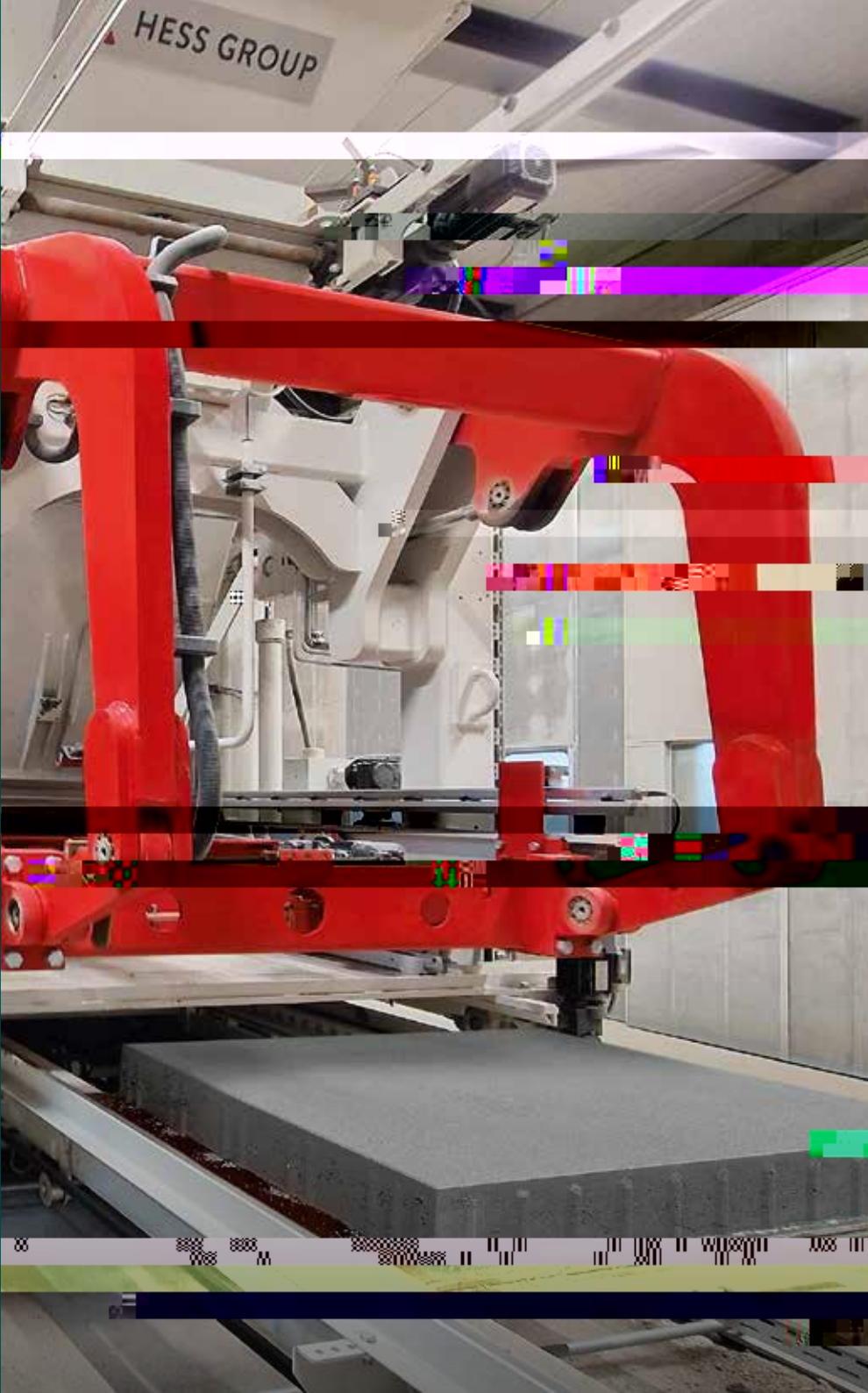

RU



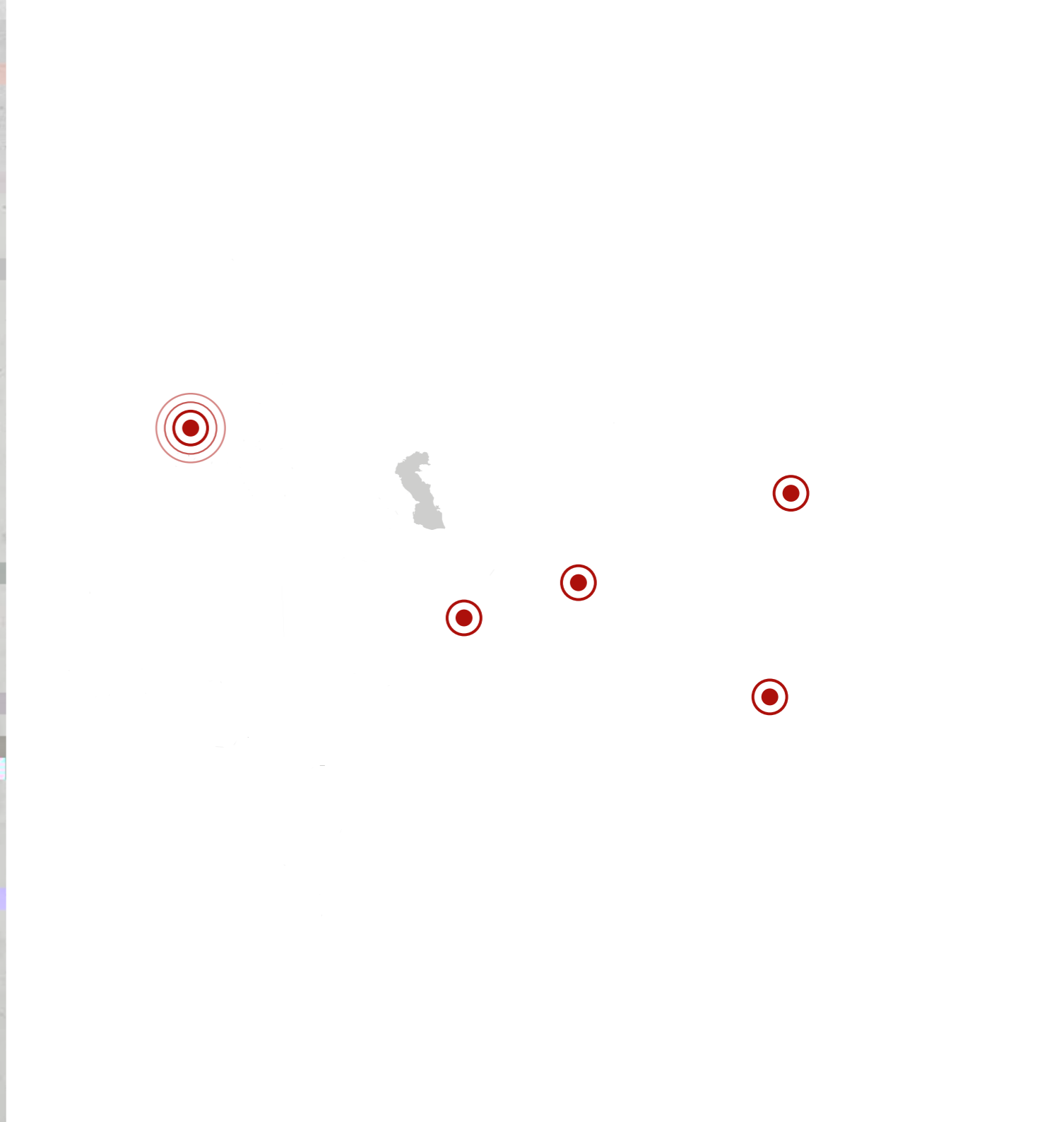
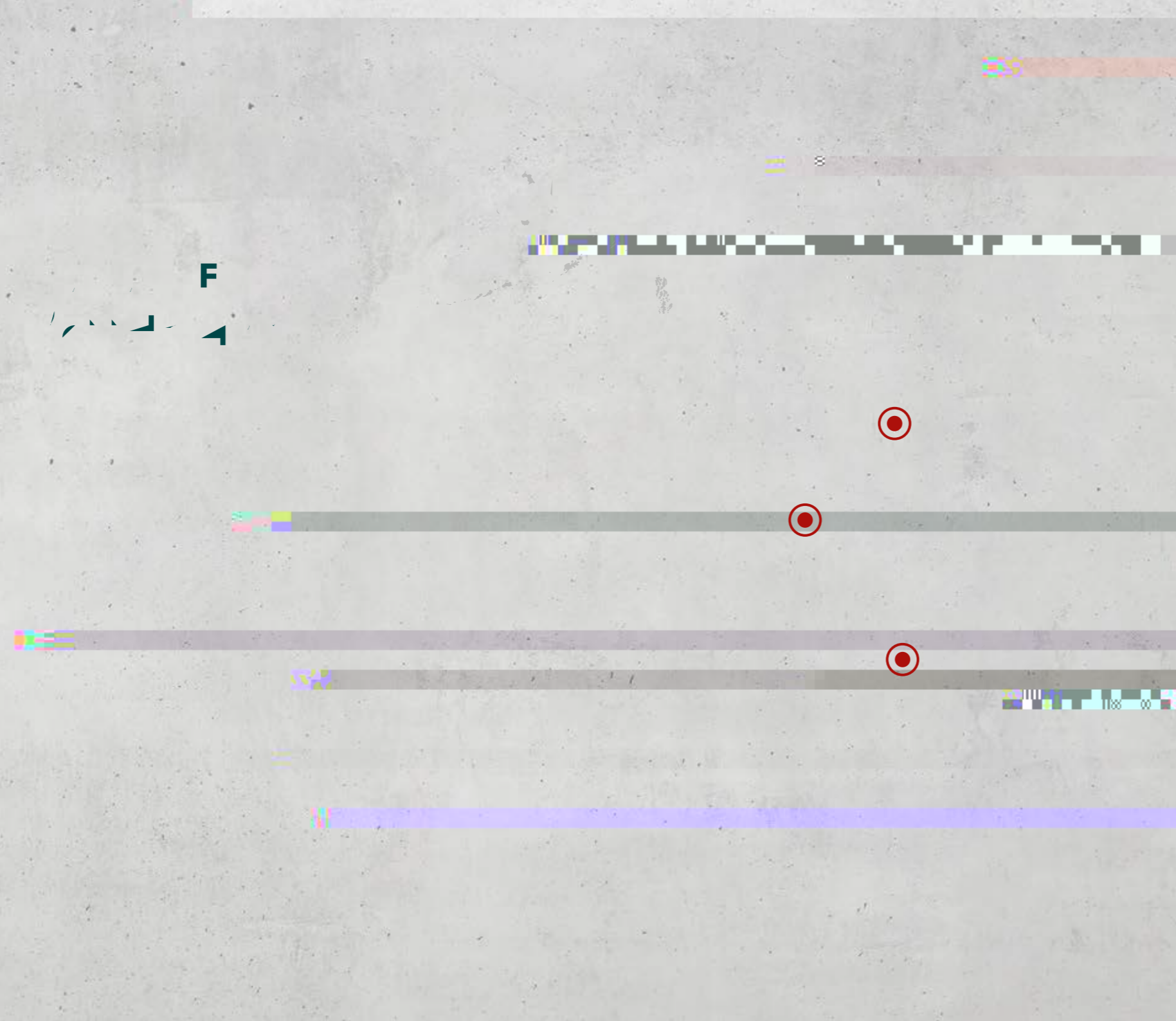
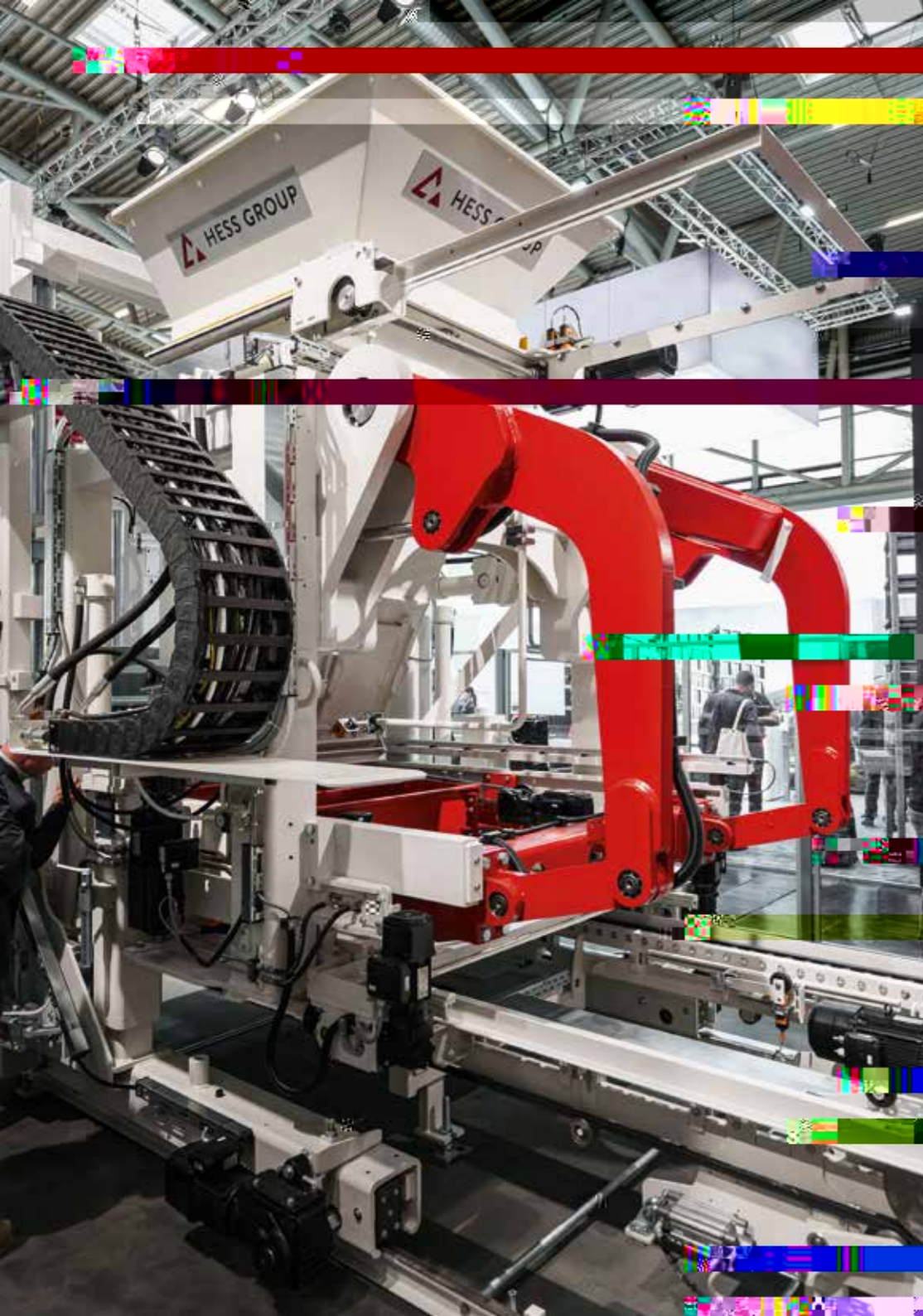

F F

F / F

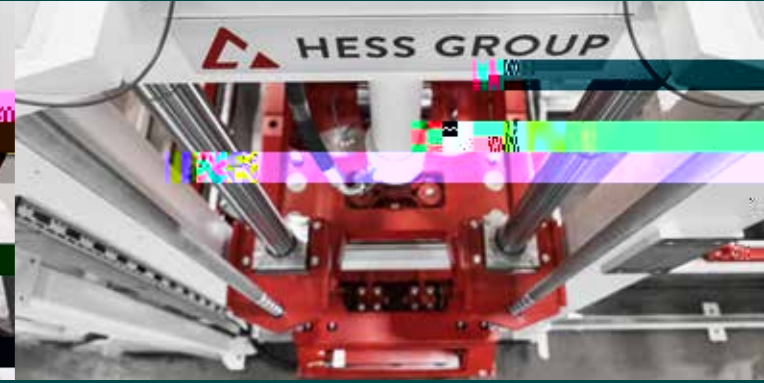

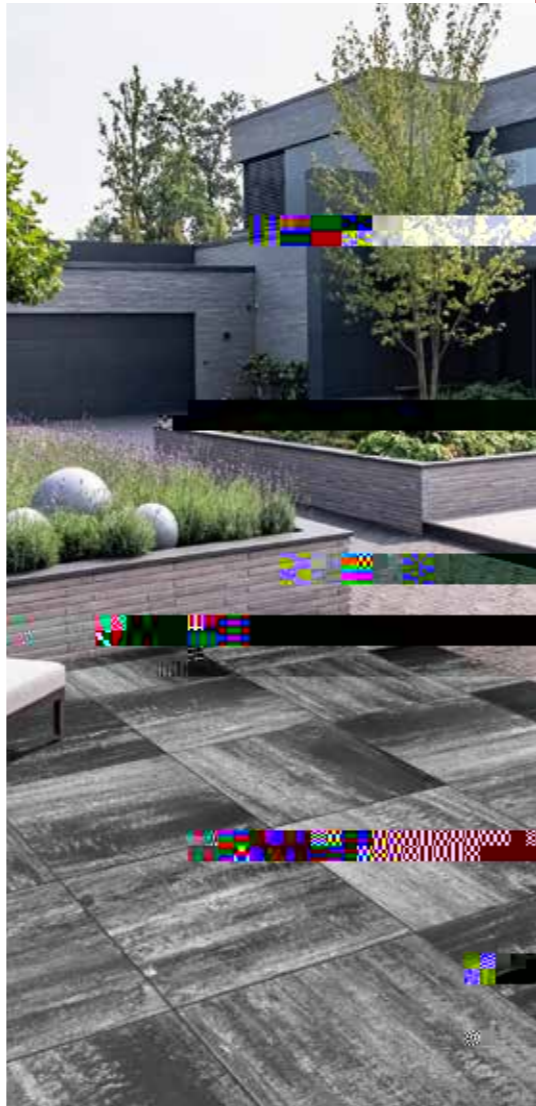
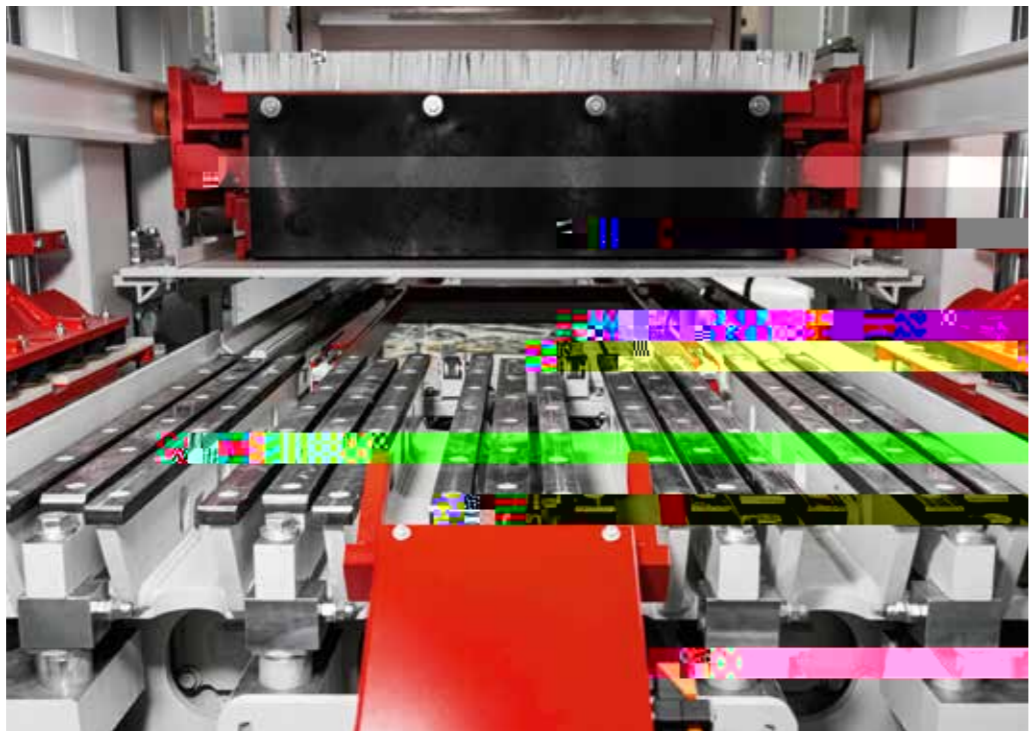
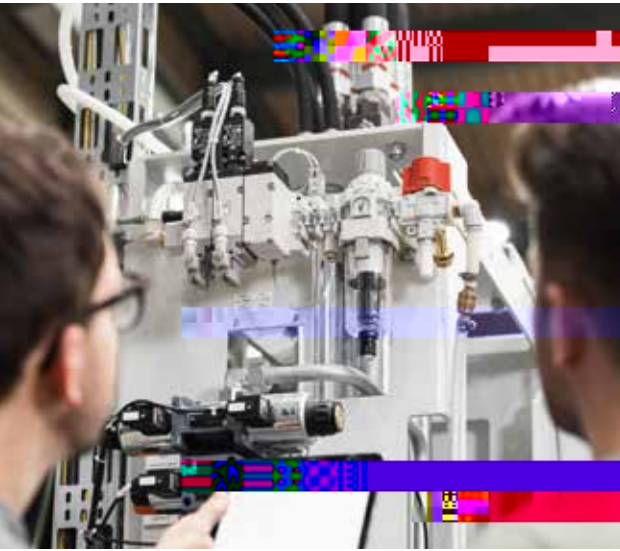

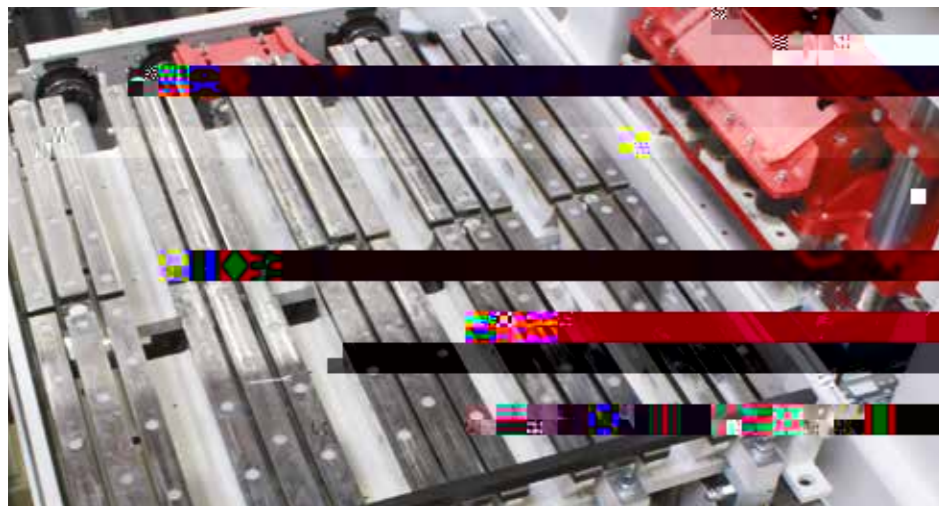

()

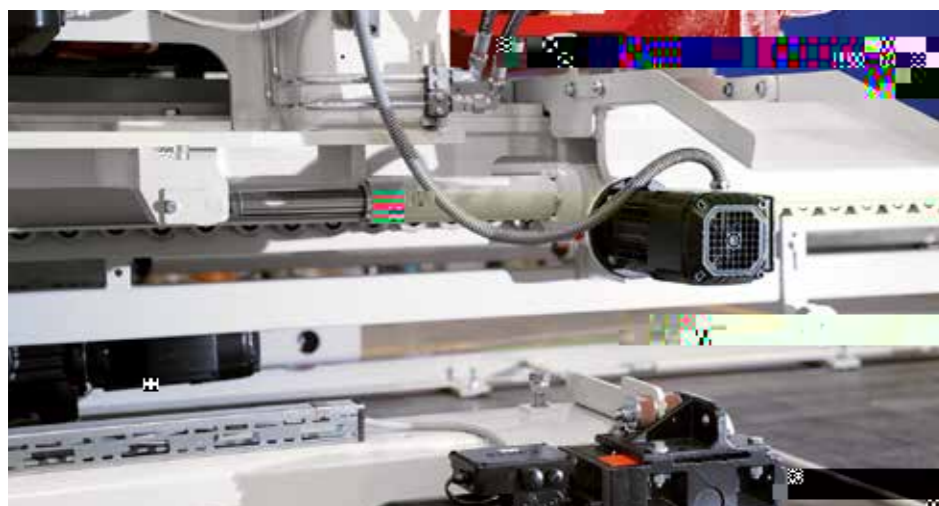
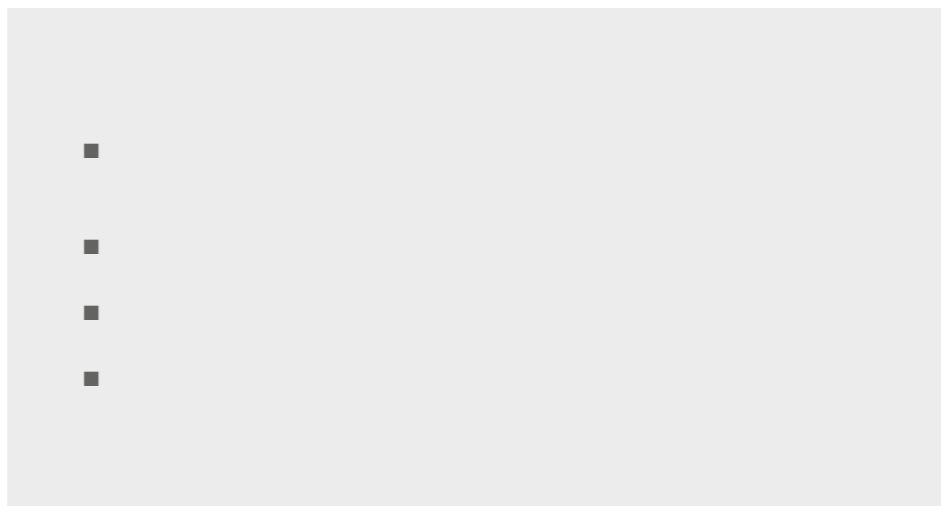

()

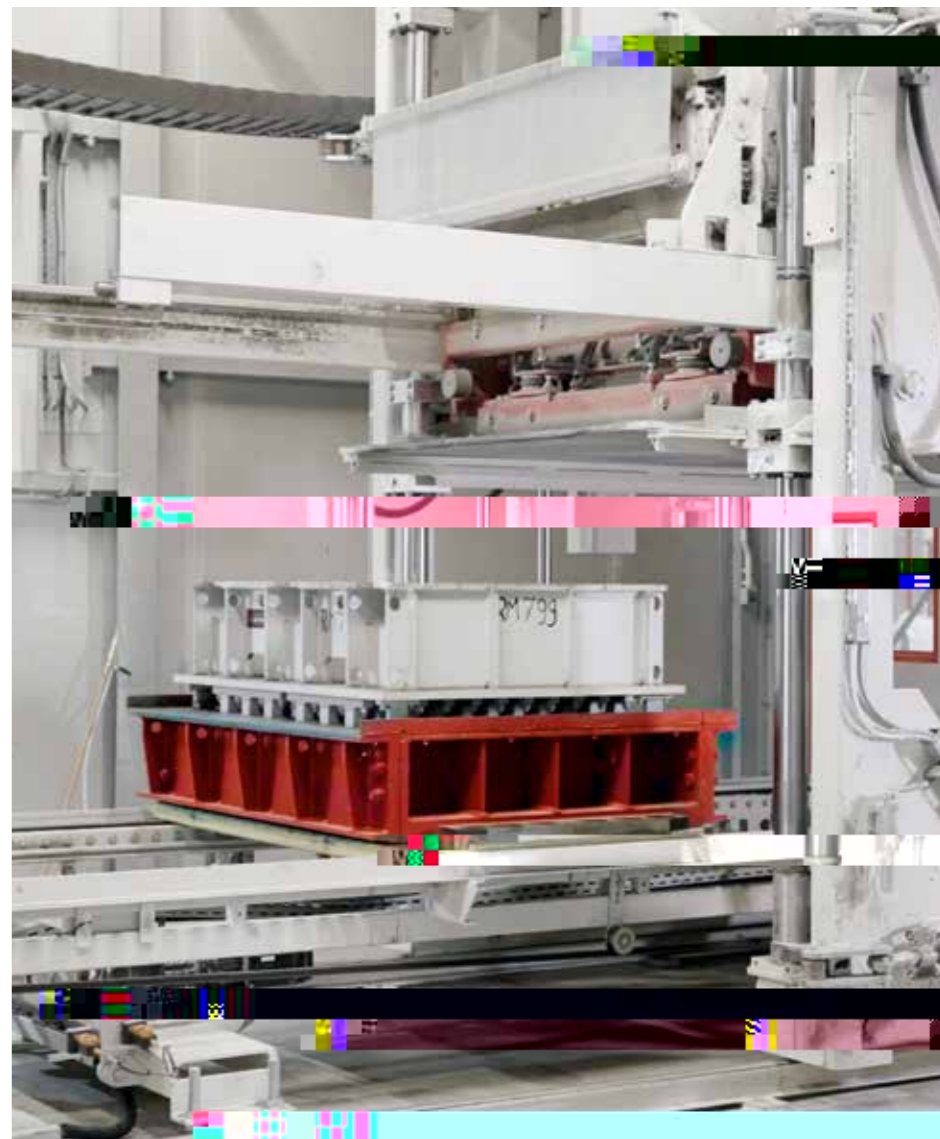
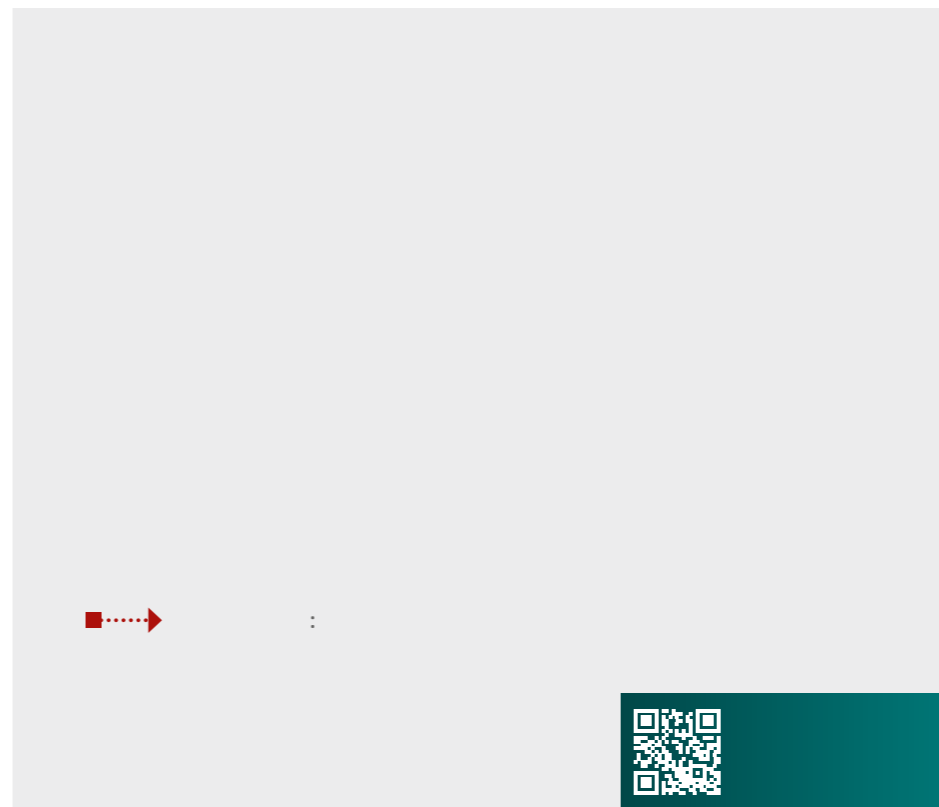
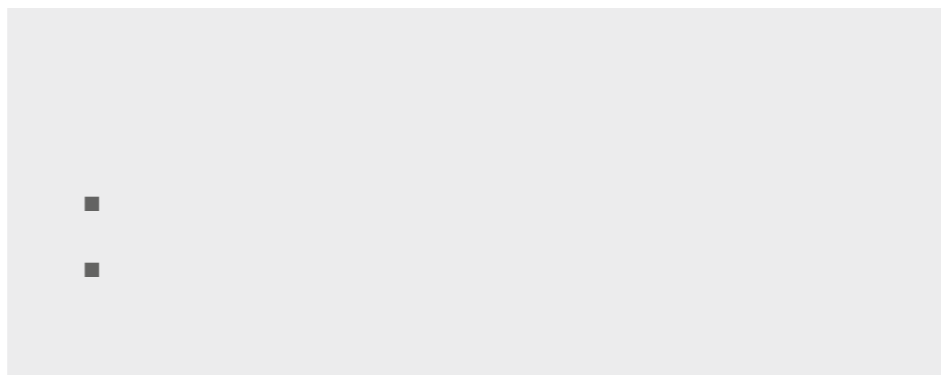

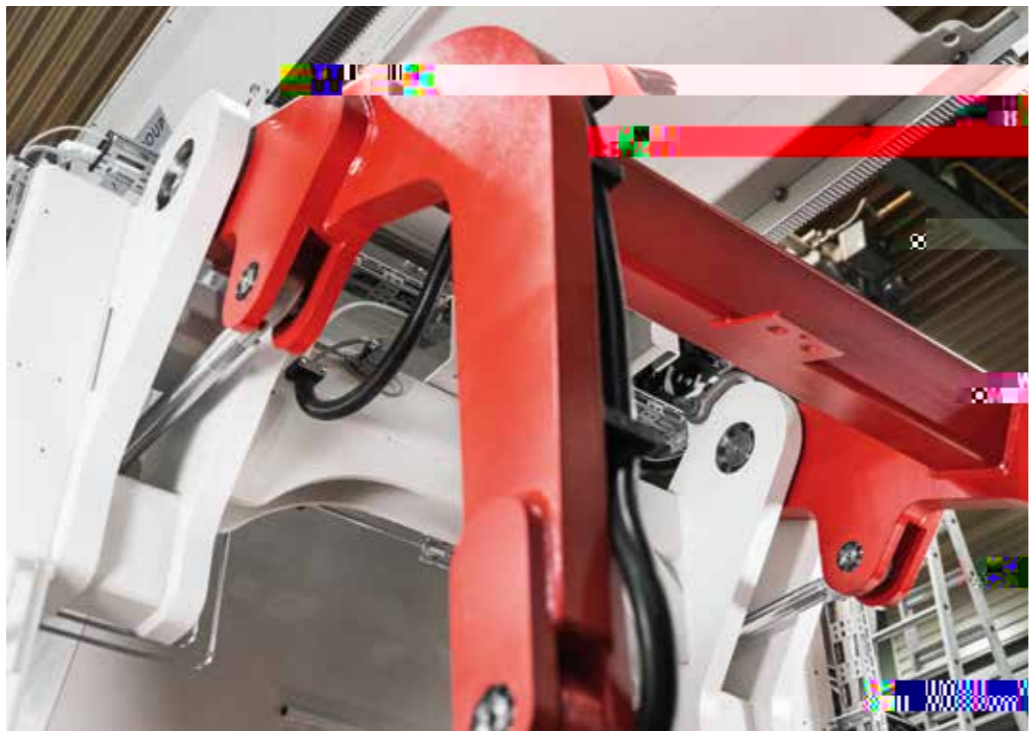

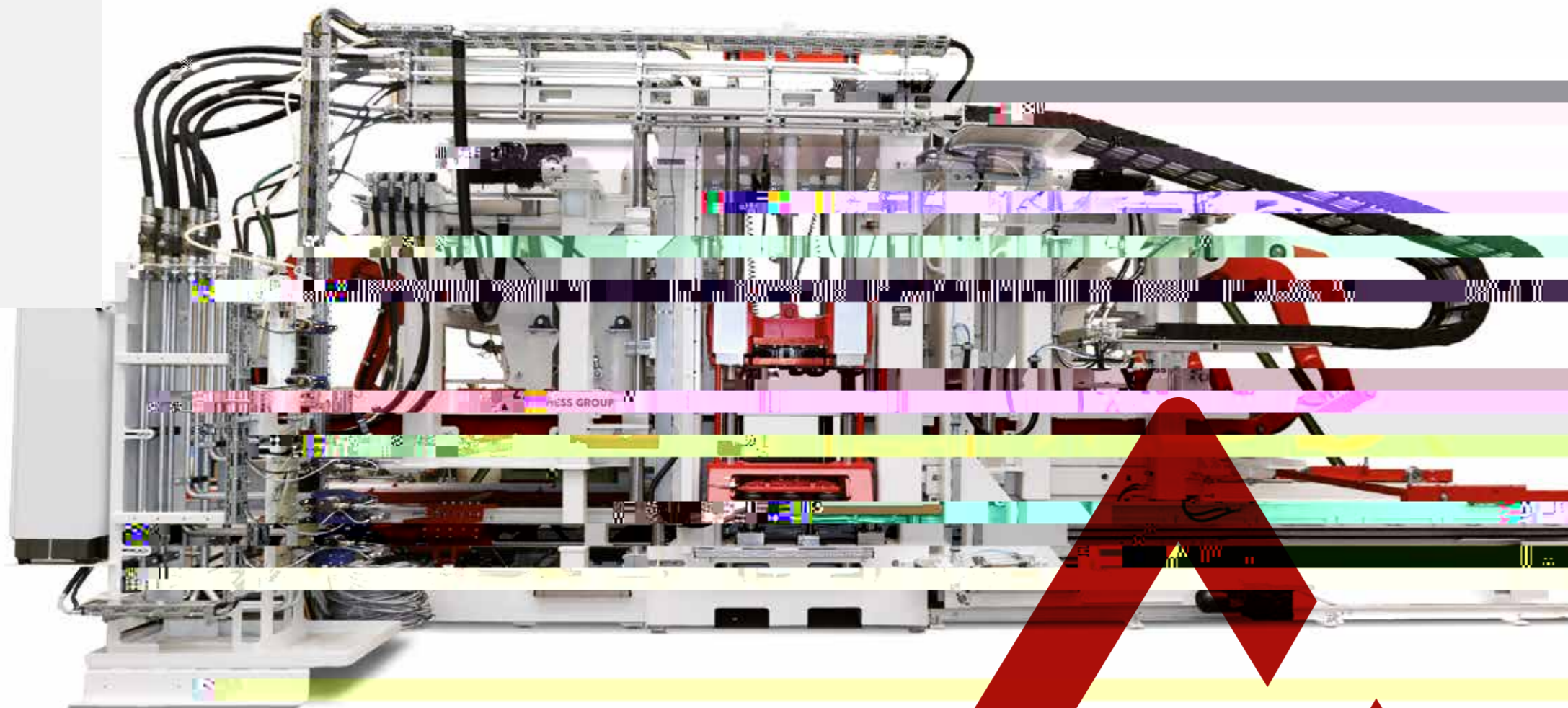

RH 1500-4 VA

*

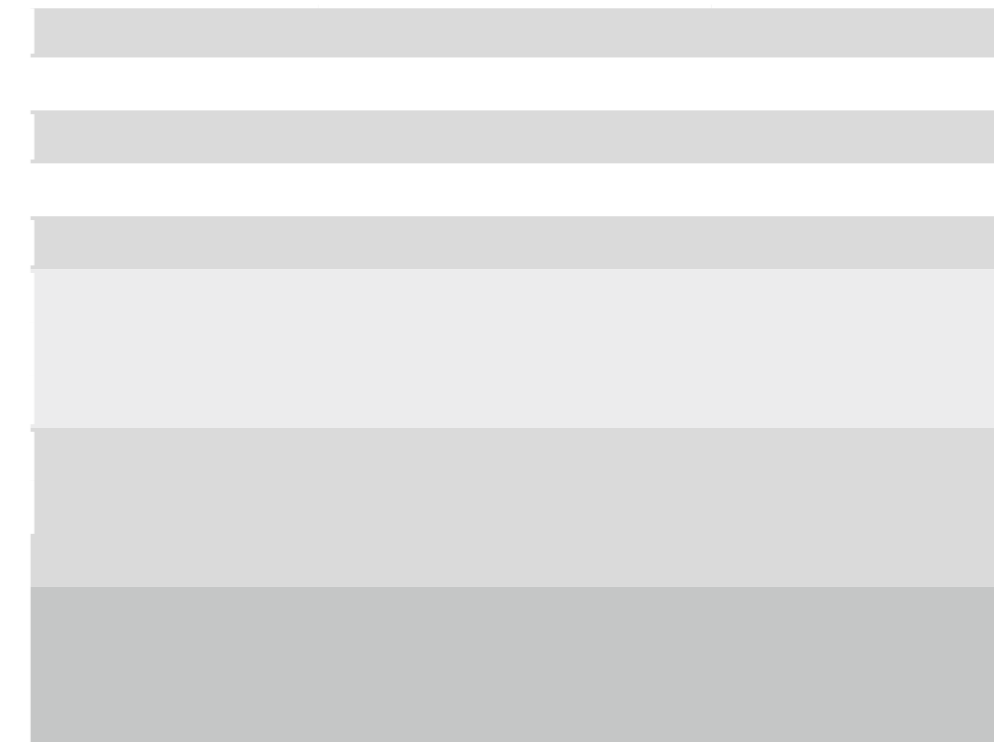

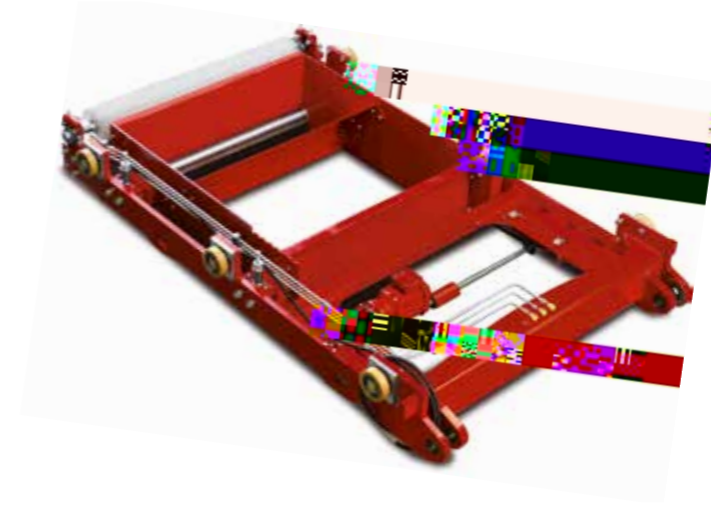
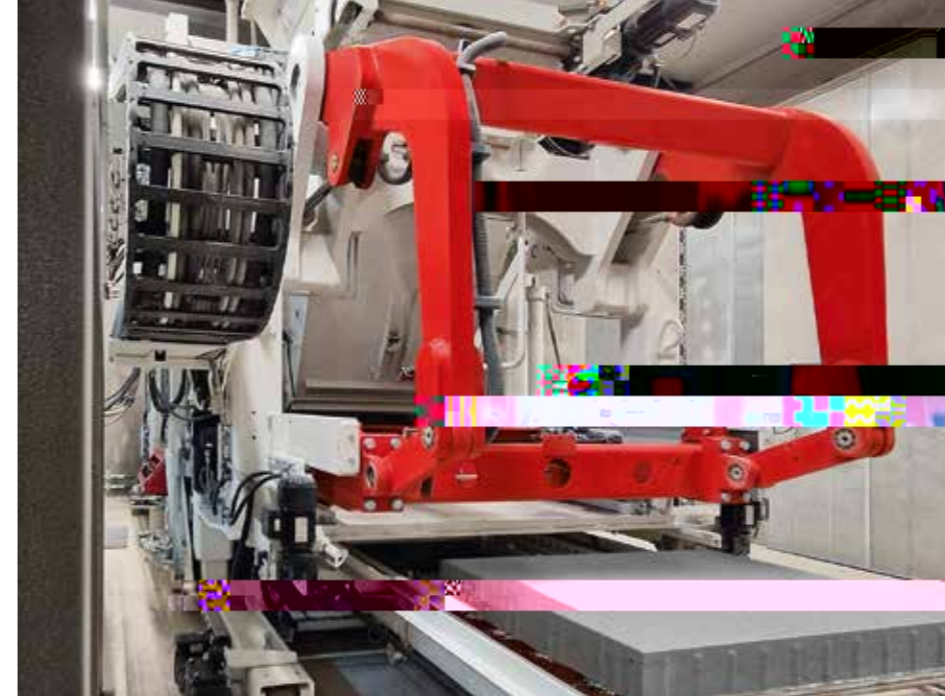

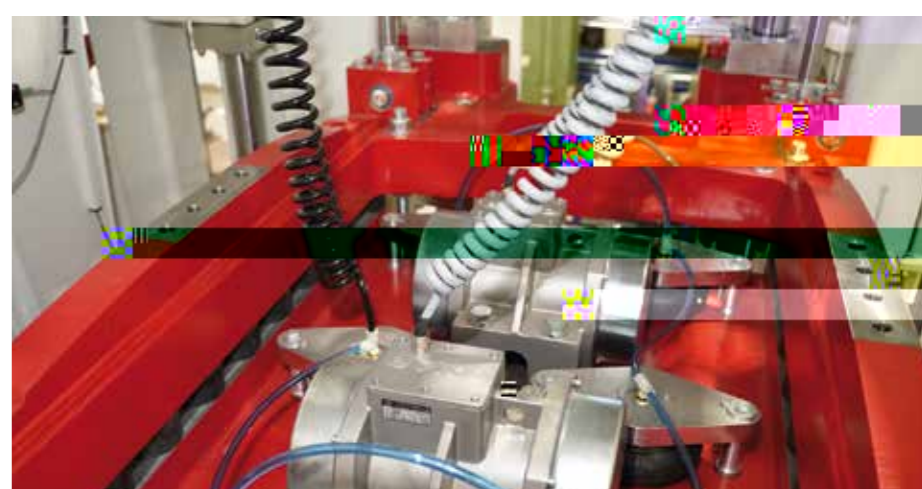
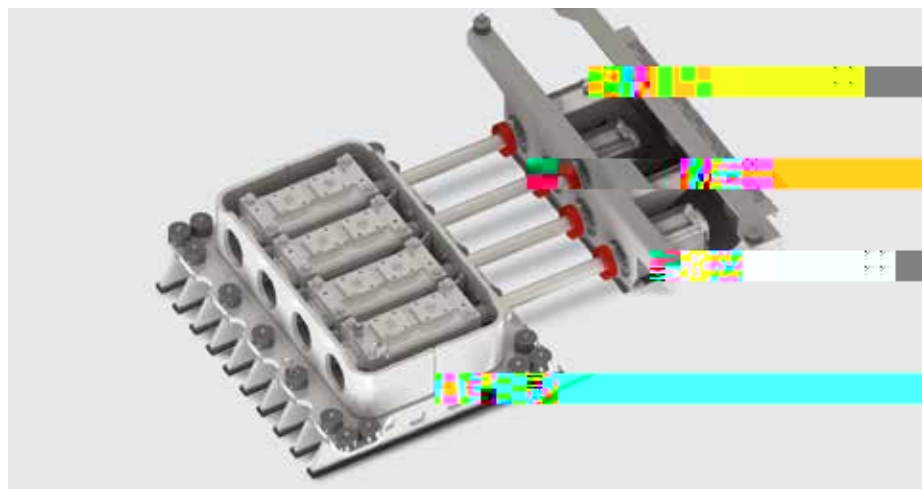
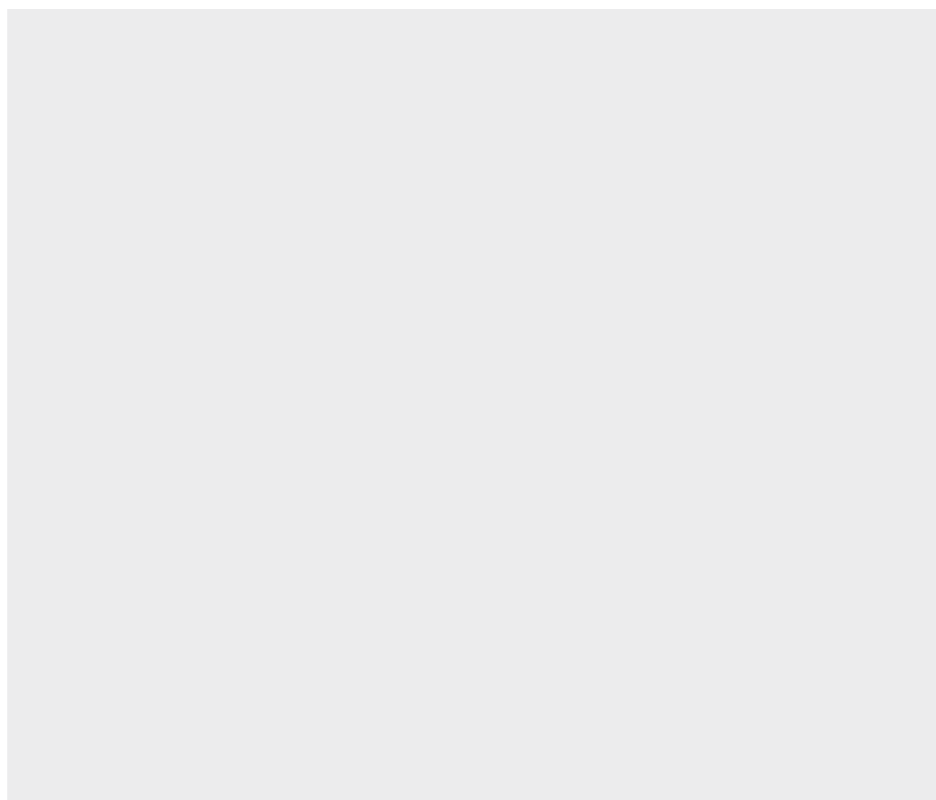

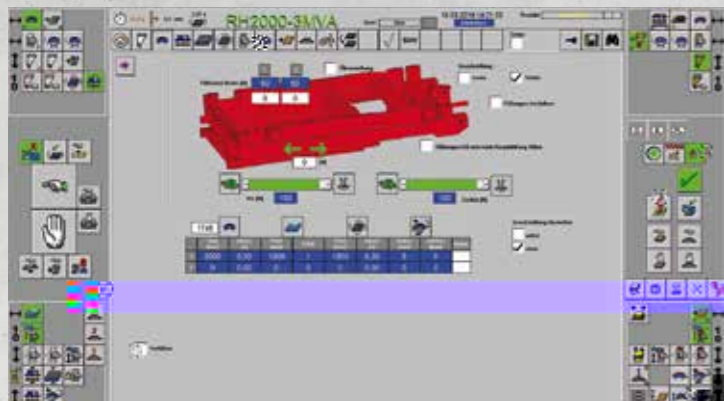

1 F

F

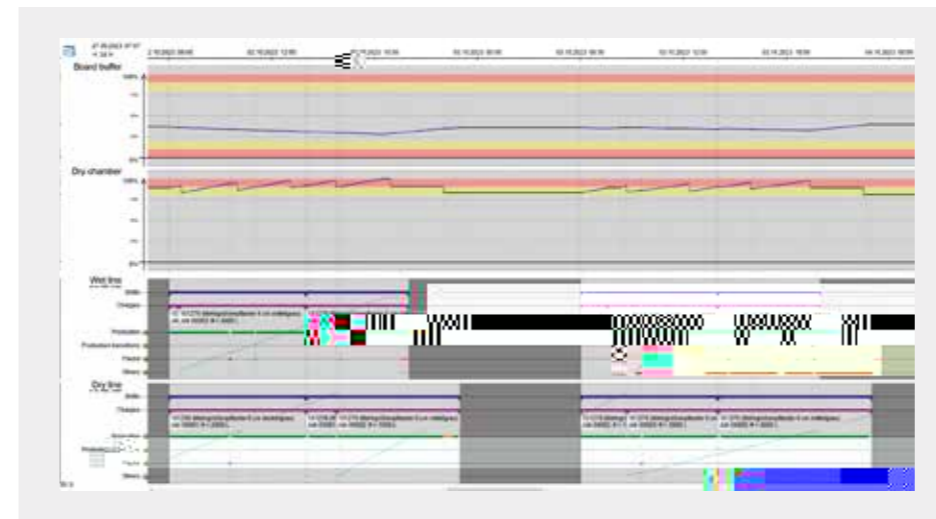

HESS GROUP

Cycle

New cycle time
Calculated by the average of the selected values

Cycle time: --- Factor: ---

Info	Frequency	Legend	31.8 / 100%	31.8 / 47%	17.1 / 57%
155 layer 05.09.2023 11:36:00 - 05.09.2023 12:54:00	60%	17% 19%	<input type="checkbox"/>	<input type="checkbox"/>	<input type="checkbox"/>
1668 layer 03.09.2023 19:00:00 - 04.09.2023 07:00:00	65%	11% 21%	<input type="checkbox"/>	<input type="checkbox"/>	<input type="checkbox"/>
604 layer 03.09.2023 15:23:00 - 03.09.23	70%	8% 11%	<input type="checkbox"/>	<input type="checkbox"/>	<input type="checkbox"/>
1413 layer 28.08.2023 13:59:00 - 29.08.2023 05:14:00	44%	30% 7% 8%	<input type="checkbox"/>	<input type="checkbox"/>	<input type="checkbox"/>
281 layer 28.08.2023 07:18:00 - 28.08.2023 13:59:00	20%	13% 10% 51%	<input type="checkbox"/>	<input type="checkbox"/>	<input type="checkbox"/>

█ Production
█ Undefined times
█ Defined wait times
█ Waiting time
█ Defined stop times
█ Stop time

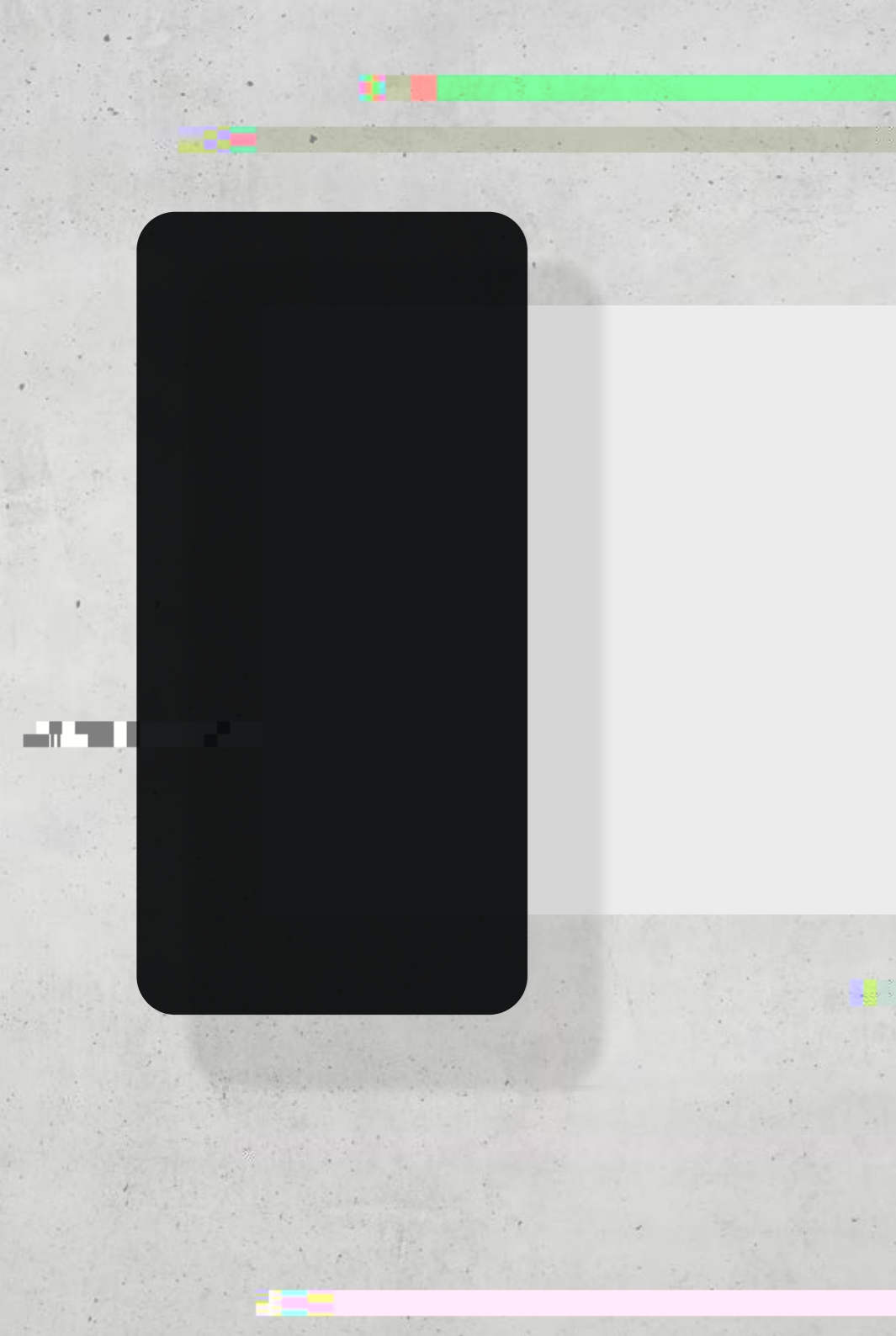

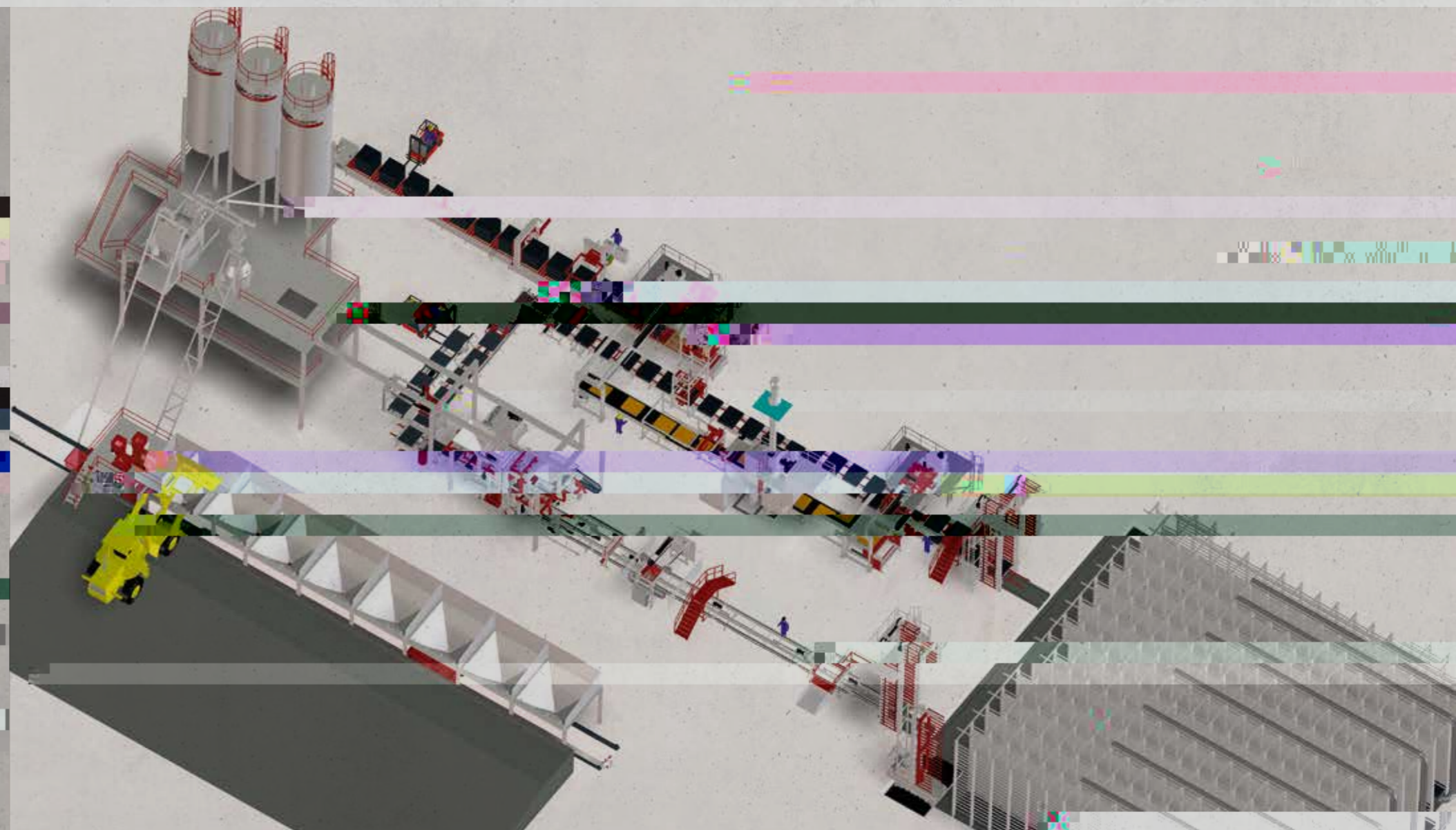
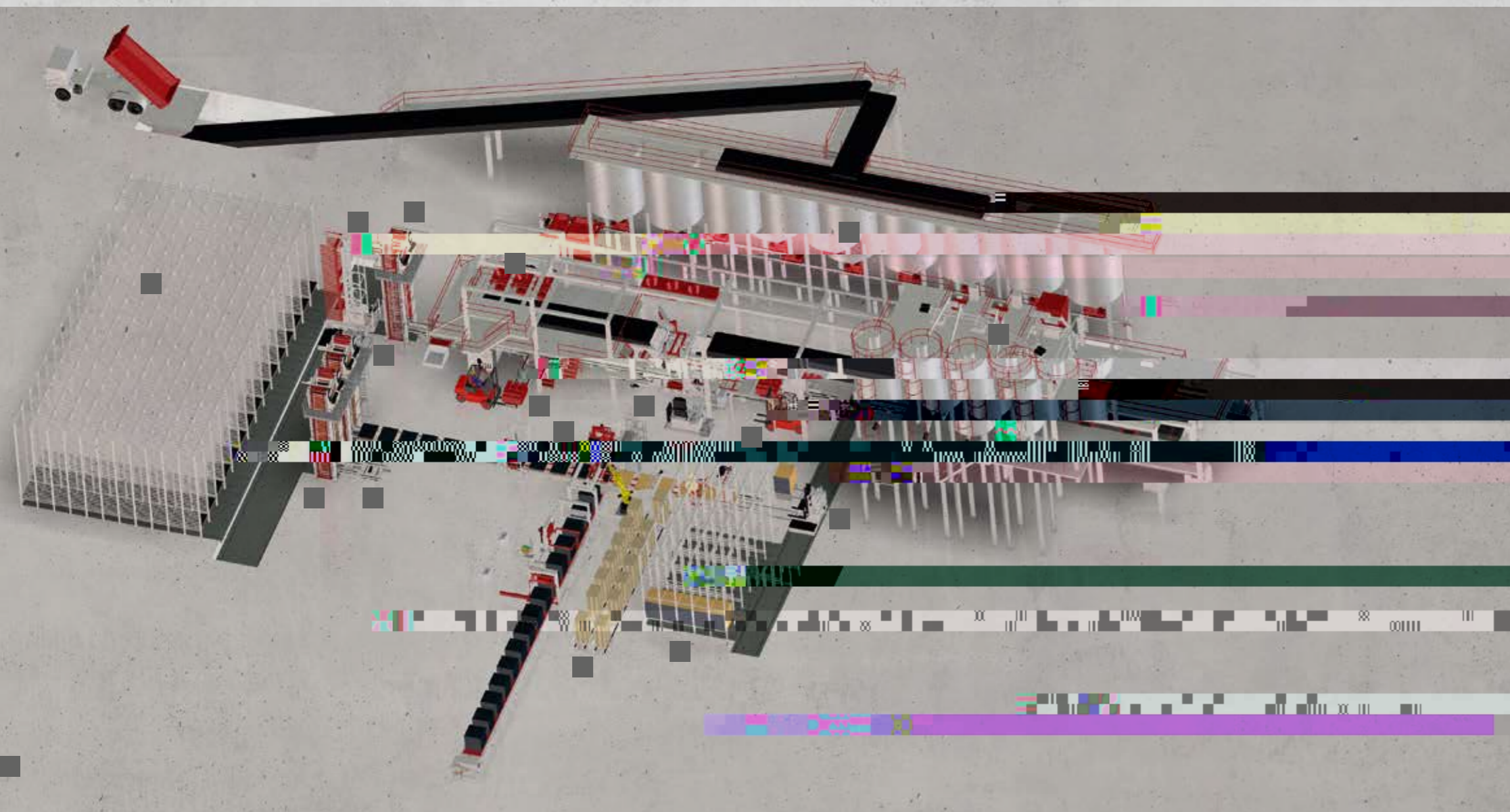



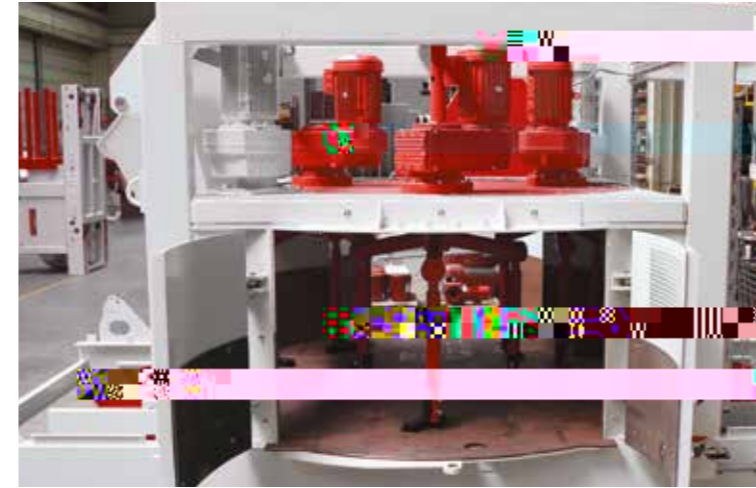

SM500

	SM500	SM1500	SM2250	SM3375	SM4500

-
-
-
-
-
-
-
-



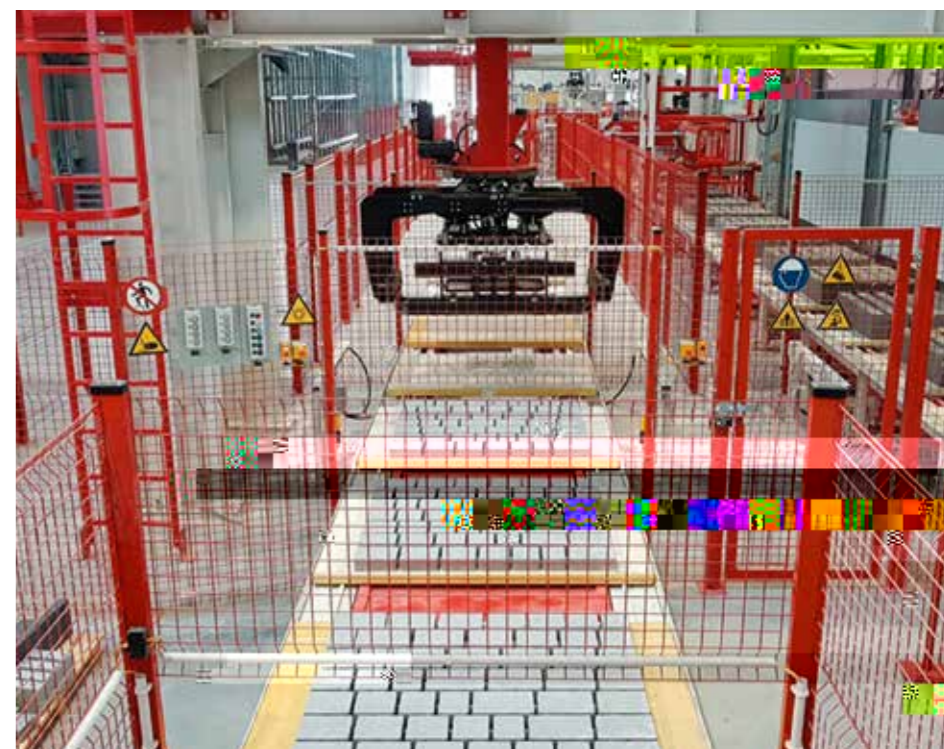
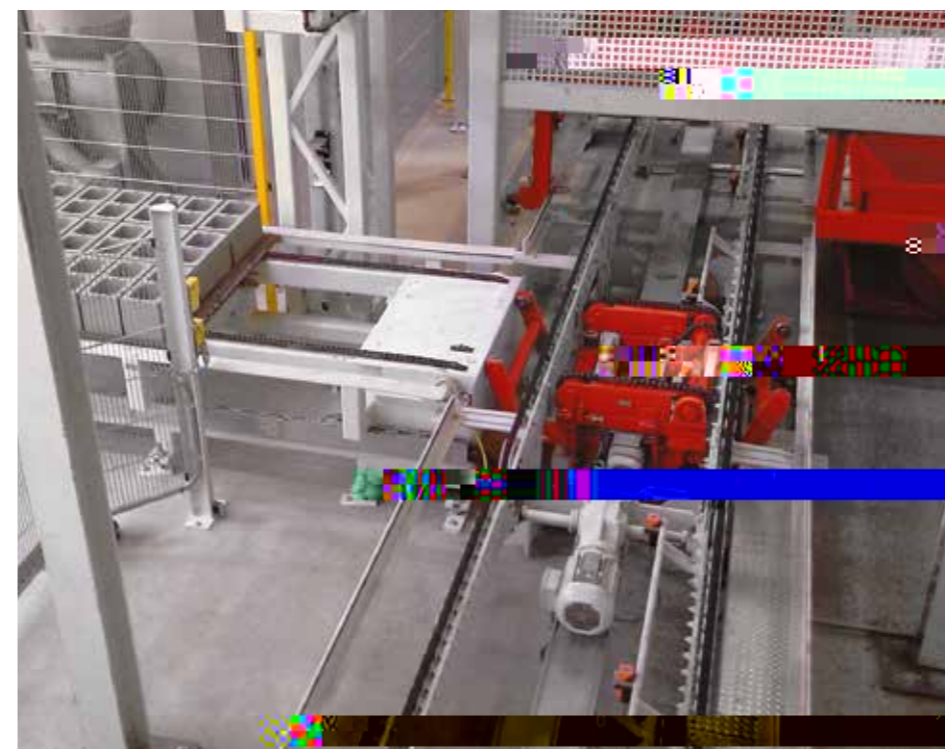
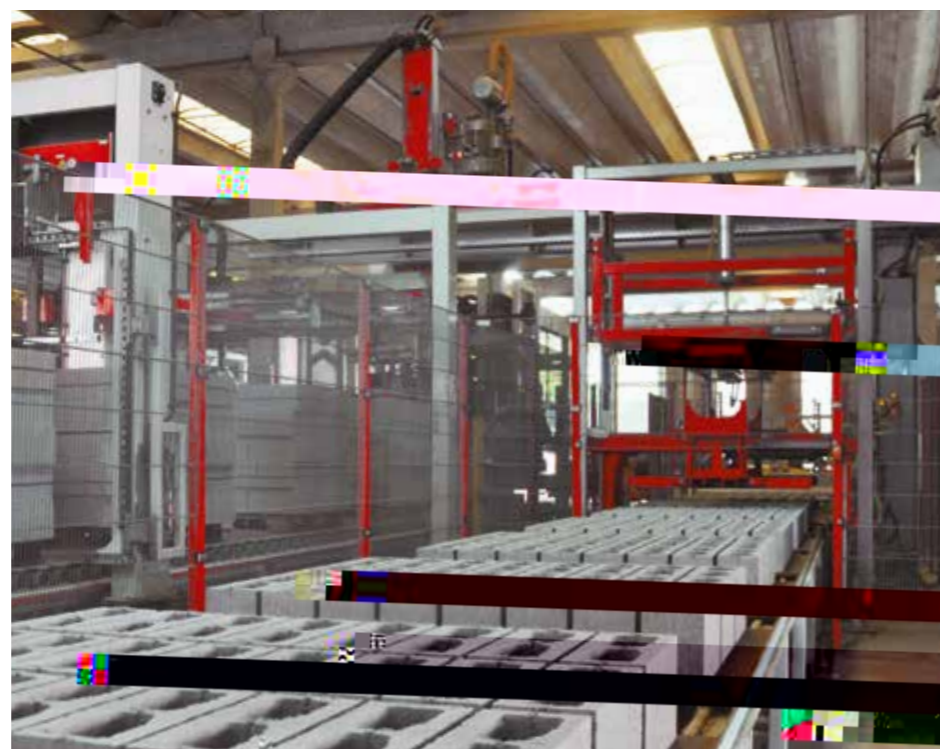

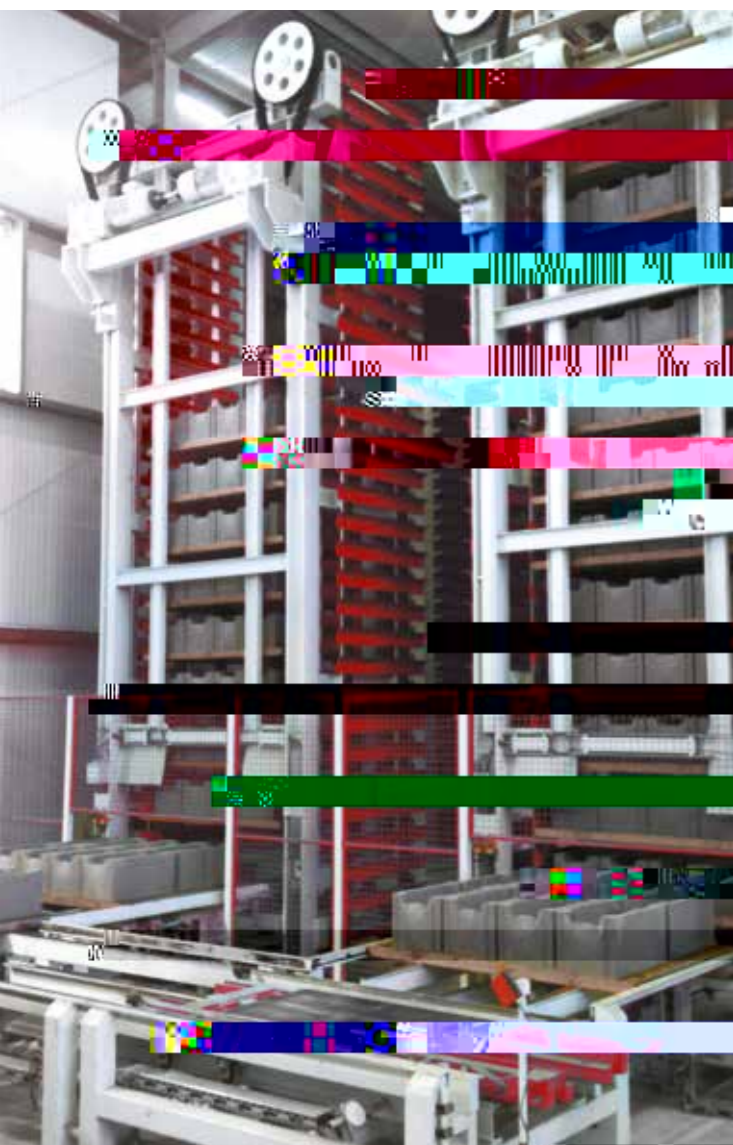

(8,5 , 14 , 24)



